

## 表面贴装成形 Surface mounted device style lead forming

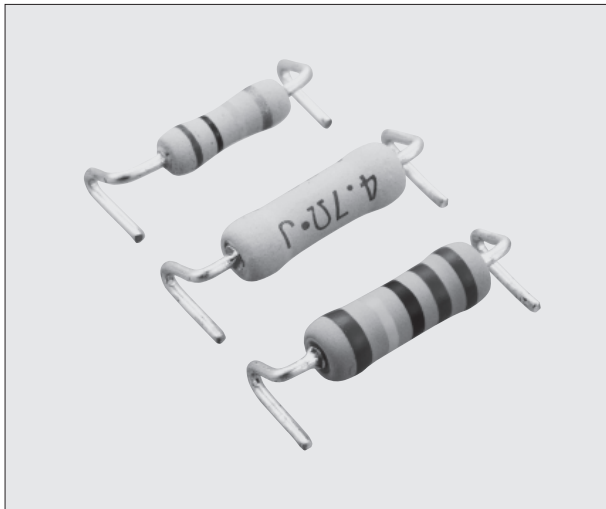

### 成形状态 Forming style

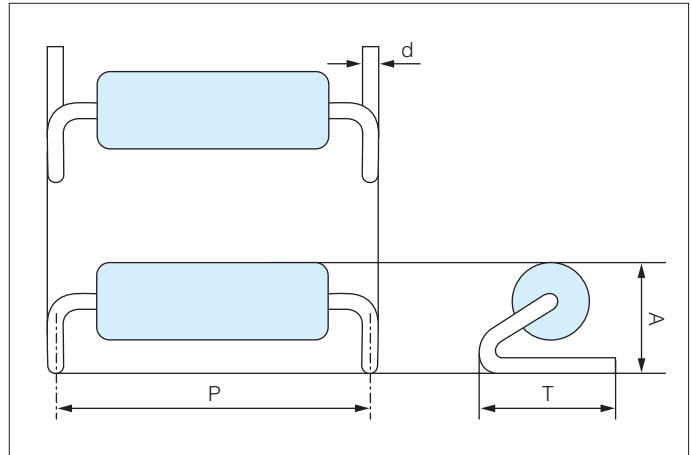

### 额定值 Ratings

型号 Type	成形产品名称 Forming Type Name	Carrier tape符号 Carrier Tape	成形尺寸 Forming Dimension (mm)				包装数量/卷 Qty/Reel (pcs)	重量 Weight (g)	
			P±1	T	A±0.5	d		卷 Reel	NET/1000pcs
MOS (X) 1	N14.5	TEB	14.5	5.0±0.5	4.8	0.8	1,000	700	350
MOS (X) 2 SPR (X) 2 RCR75 CW2	N17	TEB	17.0	6.0±0.5	5.8	0.8	1,000	900	600
MOS (X) 3 SPR (X) 3 RCR100 CW3	N20	TEG	20.0	7.5±1	6.5	0.8	900	1,800	1,400

### 包装规格 Packaging Specifications

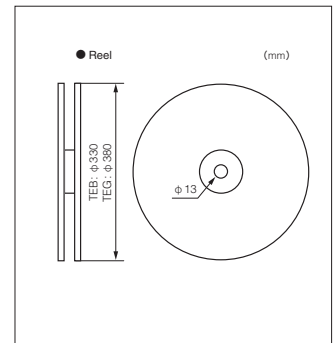
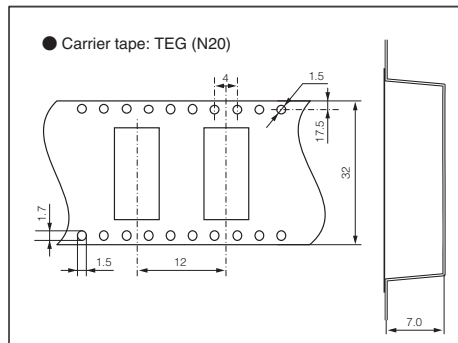
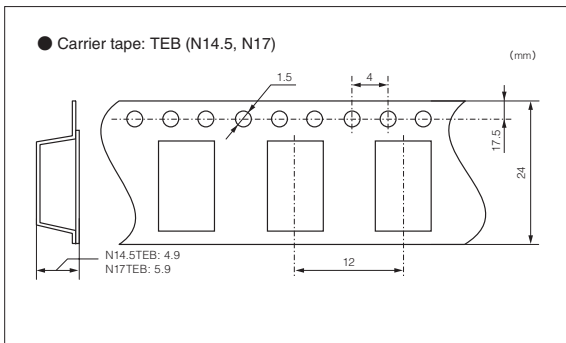

### 推荐焊接区尺寸 Recommended Pad Dimensions

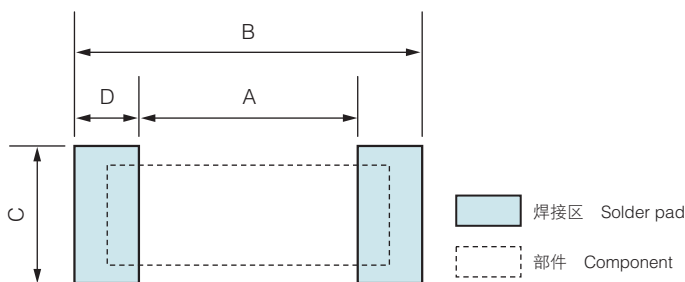

型号 Type	成形产品名称 Forming Type Name	焊接区尺寸			
		A	B	C	D
MOS (X) 1	N14.5TEB	12.5	16.5	7.0	2.0
MOS (X) 2 SPR (X) 2 RCR75 CW2	N17TEB	14.6	19.4	8.0	2.4
MOS (X) 3 SPR (X) 3 RCR100 CW3	N20TEG	17.6	22.4	9.5	2.4

- 需要使用专用喷嘴。使用时请另行咨询。
- Need a dedicated nozzle for automatic mounting. Please inquire to us before use.

包装 Packaging