

THICK FILM (LOW RESISTANCE)

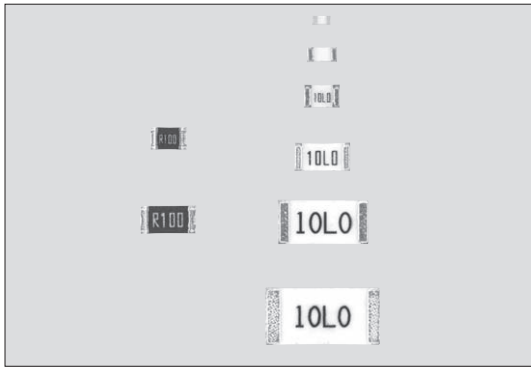

UR73 矩形低电阻片式电阻器 Low Resistance Flat Chip Resistors



外观颜色: 紫色 Coating color: Indigo

特点 Features

- 是电源电路、电动机电路等的电流检测电阻器。
- 是低电阻值 (100mΩ以下)、高精度 (±1%) 的电流检测用电阻器。
- 是电阻温度系数 ±100×10⁻⁶/K 的高信赖性、高性能品。
- 对应回流焊、波峰焊。
- 符合欧盟RoHS。
- Current detecting resistors for power supplies, motor circuits, etc.
- Low resistance (100mΩ or under) and high accuracy resistors (±1%) for current detection.
- High reliability and performance with T.C.R. ±100×10⁻⁶/K.
- Suitable for flow and reflow solderings.
- Products meet EU-RoHS requirements.

用途 Applications

- 电子计算机、HDD、手机、电源、电动机等。
- Computers, HDDs, Cellular-telephones, Power supplies, and Motor circuits, etc.

参考标准 Reference Standards

IEC 60115-8
JIS C 5201-8

※1

电阻值范围 (Ω) Resistance Value	4位显示 4 digits
10m~91m	10L0~91L0
0.1	R100

额定值 Ratings

型号 Type	额定功率 Power Rating	电阻温度系数 T.C.R. (×10 ⁻⁶ /K)	电阻值范围 Resistance Range (Ω) E24 & 25m, 50m ^{※2}	阻值允许偏差 Resistance Tolerance	额定环境温度 Rated Ambient Temp.	额定端子部温度 Rated Terminal Part Temp.	使用温度范围 Operating Temp. Range	编带和包装数/卷 Taping & Q'ty / Reel (pcs)			
								TP	TD	TE	
UR73D 1E ^{※4}	0.125W	±500 ±100	24m~27m 30m~100m	F: ±1%	70°C	-	-55°C~+125°C	10,000	-	-	
UR73D 1J	0.2W	±300 ±200 ±100	10m~27m 30m~43m 47m~100m					-	5,000	-	
UR73D 2A	0.25W	±250	10m~30m					-	5,000	-	
UR73 2A	0.25W	±250 ±100	33m~43m 47m~100m					-	5,000	-	
UR73D 2B	0.5W	±200	10m~27m					-	5,000	-	
UR73 2B	0.5W	±200 ±100	30m~43m 47m~100m					-	5,000	-	
UR73D 2H	0.75W	±250 ±100	10m~30m 33m~100m					-	90°C	-	4,000
UR73D 3A	1.0W	±250 ±100	10m~30m 33m~100m					-	95°C	-	4,000

额定电压是√额定功率×公称电阻值所算出的值。 Rated voltage = √Power Rating × Resistance value

※2 可能提供25mΩ和50mΩ的电阻。 25mΩ and 50mΩ are available.

※3 额定功率是根据下一项的表面温度上升数据做出保证的。 ※4 在使用之前请和我们联系。

本样本手册中记载的产品规格如有变更，恕不一一奉告。订购以及使用之前，请仔细确认规格表的内容。

用于车载设备、医疗设备、航空设备以及其它涉及人身安全、或可能引起重大损失的设备上时，请务必事先与我司联系。这些产品在这类用途中出现故障或失灵可能导致人身事故或严重损坏。

Specifications given herein may be changed at any time without prior notice. Please confirm technical specifications before you order and/or use.

Contact our sales representatives before you use our products for applications including automobiles, medical equipment and aerospace equipment.

Malfunction or failure of the products in such applications may cause loss of human life or serious damage.

Mar. 2015

www.koaglobal.com

结构图 Construction

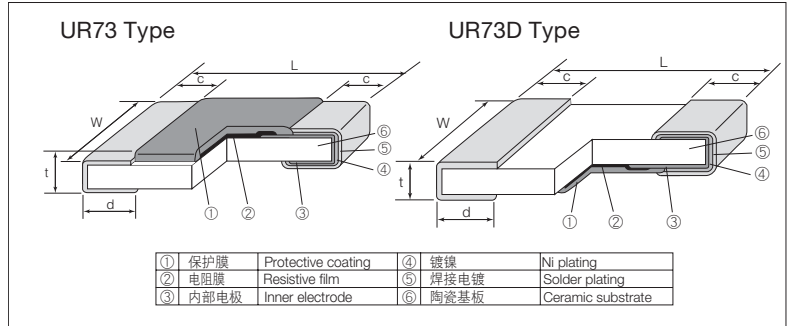

外形尺寸 Dimensions

型号 Type (Inch Size Code)	电阻值范围 (Ω) Resistance range	尺寸 Dimensions (mm)					Weight (g) (1000pcs)
		L	W	t	c	d	
UR73D 1E (0402)	24m~100m	1.0 ^{+0.1} _{-0.05}	0.5 ^{+0.1} _{-0.05}	0.4±0.05	0.25±0.1	0.3±0.1	0.72
UR73D 1J (0603)	10m~27m 30m~100m	1.6±0.2	0.8 ^{+0.15} _{-0.1}	0.5±0.1	0.35±0.1	0.55±0.1 0.35±0.1	2.84
UR73D 2A (0805)	10m~16m 18m~30m	2.0±0.2	1.25±0.2	0.55±0.1	0.4±0.2	0.6±0.2 0.5±0.2	5.74
UR73 2A (0805)	33m~100m	2.0±0.2	1.25±0.2	0.55±0.1	0.4±0.2	0.3 ^{+0.1} _{-0.1}	5.60
UR73D 2B (1206)	10m~16m 18m~27m	3.2±0.2	1.6±0.2	0.6±0.1	0.5±0.2	1.0±0.2 0.8±0.2	11.12
UR73 2B (1206)	30m~100m	3.2±0.2	1.6±0.2	0.6±0.1	0.5±0.3	0.4 ^{+0.2} _{-0.1}	10.09
UR73D 2H (2010)	10m~30m 33m~100m	5.0±0.2	2.5±0.2	0.65±0.1	0.65±0.3	1.6±0.3 0.65±0.3	29.80
UR73D 3A (2512)	10m~30m 33m~100m	6.3±0.2	3.1±0.2	0.6±0.1	0.8±0.3	2.0±0.3 0.8±0.3	47.69

品名构成 Type Designation

实例 Example

UR73	2B	T	TD	47L0	F
品种 Product Code	额定功率 Power Rating	端子表面材质 Terminal Surface Material	二次加工 Taping	公称电阻值*1 Nominal Resistance	阻值允许偏差 Resistance Tolerance
	2A: 0.25W 2B: 0.5W	T: Sn	TD: 4mm pitch punch paper BK: Bulk	4 digits Ex. 47L0: 47mΩ R100: 100mΩ	F: ±1%
UR73D	2A	T	TD	10L0	F
品种 Product Code	额定功率 Power Rating	端子表面材质 Terminal Surface Material	二次加工 Taping	公称电阻值*1 Nominal Resistance	阻值允许偏差 Resistance Tolerance
UR73D: 面朝下 Face-down	1E: 0.125W 1J: 0.2W 2A: 0.25W 2B: 0.5W 3A: 1W	T: Sn	TP: 2mm pitch punch paper TD: 4mm pitch punch paper TE: 4mm pitch plastic embossed BK: Bulk	4 digits Ex. 10L0: 10mΩ R100: 100mΩ	F: ±1%

欲知关于此产品含有的环境负荷物质详情 (除EU-RoHS以外)，请与我们联系。

编带细节请参考卷末附录C。

Contact us when you have control request for environmental hazardous material other than the substance specified by EU-RoHS.

For further information on taping, please refer to APPENDIX C on the back pages.

■ 负荷减轻特性曲线 Derating Curve

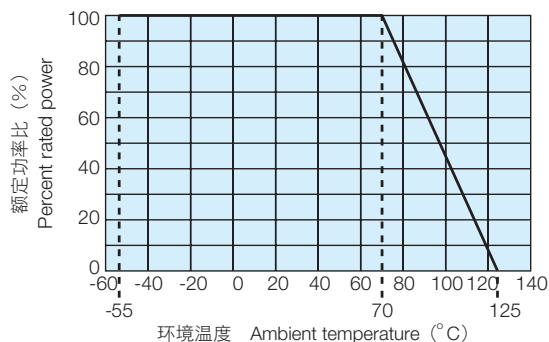

在环境温度70℃以上使用时，应按照上图负荷减轻特性曲线，减小额定功率。
For resistors operated at an ambient temperature of 70°C or above, a power rating shall be derated in accordance with the above derating curve.

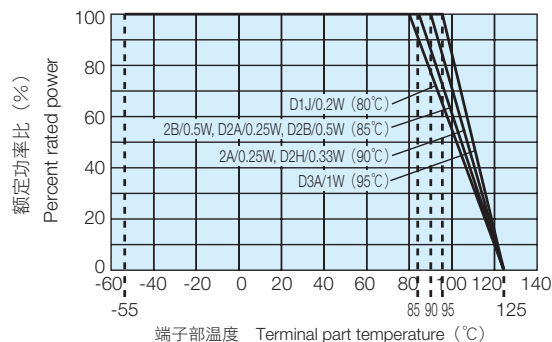

超过上述端子部温度使用时，请根据负荷减轻特性曲线减小额定功率后使用。
※有关使用方法，请参照卷首的“端子部温度负荷减轻特性曲线的说明”。

For resistors operated terminal part temperature of described for each size or above, a power rating shall be derated in accordance with derating curve.

※Please refer to “Introduction of the derating curves based on the terminal part temperature” on the beginning of our catalog before use.

■ 温度上升 Temperature Rise

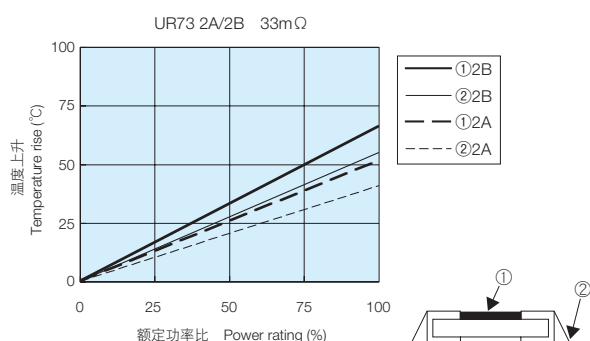

表面温度上升，由于是用本公司测定条件测定的，根据使用状况、使用基板不同，数值也会不同。

Regarding the temperature rise, the value of the temperature varies per conditions and board for use since the temperature is measured under our measuring conditions. Please inquire of us if the component is used at

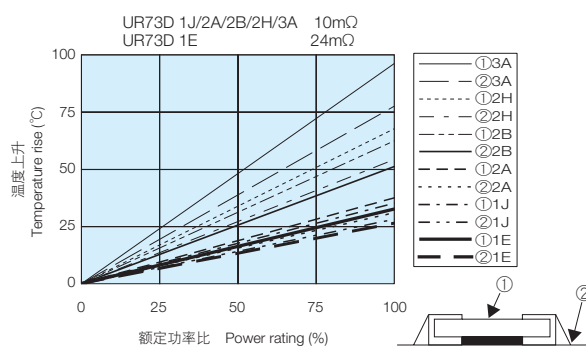

■ 性能 Performance

试验项目 Test Items	标准值 Performance Requirements $\Delta R \pm$ (%+0.005 Ω)		试验方法 Test Methods
	保证值 Limit	代表值 Typical	
电阻值 Resistance	在规定的允许偏差内 Within specified tolerance		25°C
电阻温度系数 T.C.R.	在规定值以内 Within specified T.C.R.		+25°C/-55°C and +25°C/+125°C
过载(短时间) Overload (Short time)	2	0.5	额定电压×2.5倍施加5秒钟 Rated voltage ×2.5 for 5s
耐焊接热 Resistance to soldering heat	1	0.3	260°C±5°C, 10s±1s
温度突变 Rapid change of temperature	1	0.5	-55°C (30min.) /+125°C (30min.) 100 cycles
耐湿负荷 Moisture resistance	2	1	40°C±2°C, 90%~95%RH, 1000h 1.5小时ON、0.5小时OFF的周期 1.5h ON/0.5h OFF cycle
在70°C时的耐久性 Endurance at 70°C	2	1	70°C±2°C, 1000h 1.5小时ON、0.5小时OFF的周期 1.5h ON/0.5h OFF cycle
高温放置 High temperature exposure	1	0.3	+125°C, 1000h

■ 使用注意事项 Precautions for Use

- 片状电阻器的基材是氧化铝。由于和安装基板的热膨胀系数不同，在反复提供热循环等热应力时，结合部的焊锡（焊缝部）有时会发生裂纹。特别是大型尺寸2H/3A，由于热膨胀大，而且自身发热也大，环境温度的变动有大的反复和载荷启闭有反复时，需要注意裂纹的发生。用环氧树脂印刷电路板（FR-4）作一般性热循环试验，在使用温度范围的上下限进行时，1J~2B的类型，不容易发生裂纹，而2H/3A型，则有易于发生裂纹的倾向。由于热应力而发生裂纹，取决于安装的焊接区的大小、焊接量、安装基板的散热性等。因此，在环境温度有大的变化和载荷 ON / OFF 使用条件时，应充分注意后进行设计。
- 在50mΩ以下的电阻值中，根据焊盘图案的大小和接续焊接的量，焊接后的电阻值会有变动。应事前在确认电阻值降低·上升的影响后，进行设备设计。
- The substrate of chip resistors is alumina. Cracks may occur at the connection of solder (solder fillet portion) due to the difference of the coefficient of thermal expansion from a mounting board when heat stress like heat cycle, etc. are repeatedly given to them. Care should be taken to the occurrence of the cracks when the change in ambient temperature or ON/OFF of load is repeated, especially when large types of 2H/3A which have large thermal expansion and also self heating. By general temperature cycle test using glass-epoxy (FR-4) boards under the maximum/minimum temperatures of operating temperature range, the crack does not occur easily in the types of 1J~2B, but the crack tends to occur in the types of 2H/3A. The occurrence of the crack by heat stress may be influenced by the size of a pad, solder volume, heat radiation of mounting board etc., so please pay careful attention to designing when a big change in ambient temperature and conditions for use like ON/OFF of load can be assumed.
- In the resistance values of 50mΩ or under, the resistance value after soldering may change depending on the size of pad pattern or solder amount. Make sure the effect of decline/increase of resistance value before designing.