

CCF 片式电流保险丝 Chip Current Fuses

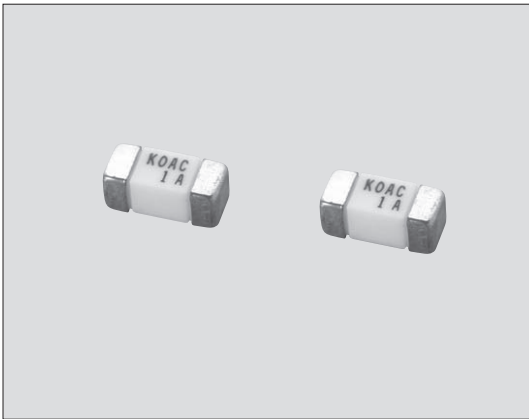

外观颜色：白色 Body color: White

特点 Features

- 可以在表面封装型一阶电路和二阶电路中的电流保险丝。
- 采用了陶瓷本体，具有优异的机械强度。
- 生产方法独特，熔断特性稳定。
- 优秀的抗浪涌性。
- 对应回流焊接和波峰焊。
- 端子无铅品，符合欧盟RoHS。
- Surface mounting fuses suitable for primary and secondary circuits.
- Excellent mechanical strength with ceramic body.
- Stable fusing characteristics due to the original technology.
- Excellent Anti-Surge characteristics.
- Products with lead free termination meet EU-RoHS requirements.

取得规格 Approvals Awarded

电气用品安全法 (1~10A) B种
PSE (1~10A) Class B
UL248.14 File No.E171861 (250mA~15A)
c-UL(CSA)C22.2 No.248.14 File No.E171861
(250mA~15A)

额定值 Ratings

型号 Type	额定电流 Rated Current	额定电压 Rated Voltage	断路容量 Interrupting Capacity	熔断特性 Fusing Characteristics		内部电阻值 Internal R. (mΩ) Max.	公称熔断值 Normal Melting I ² t (A ² ·s)	编带和包装数/卷 Taping & Q'ty/Reel (pcs)
				额定电流 Rated Current	熔断时间 Fusing Time			TE
CCF1N0.4	400mA	UL (c-UL)	UL (c-UL)	UL (c-UL) 100% 200%	4h Min. 1s Max.	650	0.024	1,000
CCF1N0.5	500mA	AC 125V	AC 125V 50A			510	0.030	
CCF1N0.63	630mA	DC 60V	DC 60V 50A			390	0.052	
CCF1N0.8	800mA	(DC 160V)	(DC 160V)	250	0.125			
CCF1N1	1A	电气安全法 PSE AC 100V	电气安全法 PSE AC 100V 100A	电气安全法 PSE 130% 160% 200%	4h Min. 1h Max. 1s Max.	90.4	0.156	
CCF1N1.25	1.25A					75.9	0.220	
CCF1N1.6	1.6A					59.3	0.513	
CCF1N2	2A					42.9	0.814	
CCF1N2.5	2.5A					36.6	1.31	
CCF1N3.15	3.15A	UL (c-UL) AC 125V DC 60V (DC 160V)	UL (c-UL) AC 125V 50A DC 60V 50A (DC 160V)	UL (c-UL) 100% 200%	4h Min. 1s Max.	26.0	2.37	
CCF1N4	4A					20.1	3.85	
CCF1N5	5A					15.3	6.5	
CCF1N6.3	6.3A					11.4	10.6	
CCF1N7	7A					10.6	12.8	
CCF1N8	8A	UL (c-UL) AC 65V DC 65V	UL (c-UL) AC 65V 50A DC 65V 50A	UL (c-UL) 100% 200%	4h Min. 60s Max.	9.5	17.0	
CCF1N10	10A					7.5	27.7	
CCF1N12	12A					4.5	73.5	
CCF1N15	15A					3.5	125.5	

使用温度范围：-55℃~+125℃

Operating Temp. Range: -55℃~+125℃

结构图 Construction

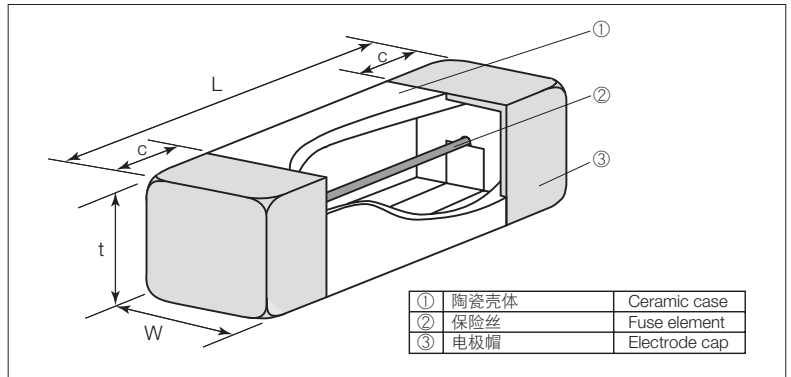

外形尺寸 Dimensions

型号 Type (Inch Size Code)	尺寸 Dimensions (mm)				Weight (g) (1000pcs)
	L±0.2	W±0.2	t±0.2	c±0.2	
CCF1N (2410)	6.0	2.5	2.5	1.4	140

品名构成 Type Designation

实例 Example

CCF	1	N	1		T	TE
品种 Product Code	形状 Style	熔断特性 Fusing Characteristics N:普通熔断 N:Normal blow	额定电流 Rated Current	额定电压 (UL) Rated Voltage (UL) 空栏 Nil: 125V.a.c./60V.d.c. or 65V.a.c./65V.d.c. D: 125V.a.c./160V.d.c.	端子表面材质 Terminal Surface Material T: Sn (Nil: Sn/Pb)	二次加工 Taping TE:4mm pitch plastic embossed BK: Bulk

端子表面材质，以无铅品为准。

欲知关于此产品含有的环境有害物质详情(除EU-RoHS以外)，请与我们联系。编带细节请参考卷末附录C。

The terminal surface material lead free is standard.

Contact us when you have control request for environmental hazardous material other than the substance specified by EU-RoHS.

For further information on taping, please refer to APPENDIX C on the back pages.

用途 Applications

- 笔记本电脑用电源 Power supplies for note PCs
- 液晶Inverter电源 Power supplies for LCD inverters
- 照明用Inverter电源 Power supplies for Illumination inverters
- 复印机、LBP Copying machines, Laser beam printers
- 工业用机器 Industrial equipment

■ 降低额定值 Derating

● 稳恒电流 Stationary current

稳恒电流在重复脉冲时，稳恒电流波形的峰值是恒稳电流值。

Regard the peak of stationary current waveform as stationary current value when the stationary current is repeated pulse.

● 通常降低额定值 Normal derating

本产品的通常降低额定值为标准应在0.7以下。

Normal derating of this product should be 0.7max. as standards.

● 温度降低额定值 Deratings by ambient temperatures

如果在常温(25°C±5°C)以外的环境温度条件下使用本产品，必须进行温度修正，请参考右图的降低额定值系数。

When using the products at the temperatures other than normal temperature (25°C±5°C), temperature adjustment will be required. Please refer to the derating coefficient as shown in the figure.

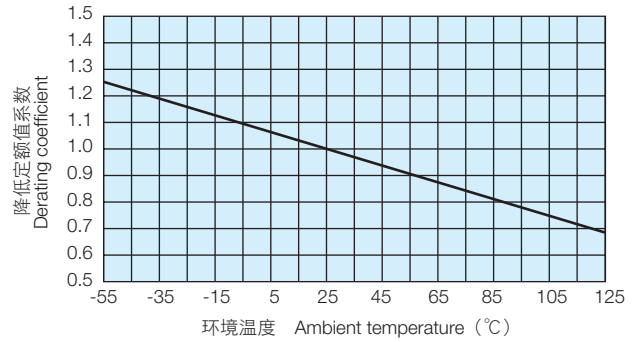

■ 熔断特性 Fusing Characteristics

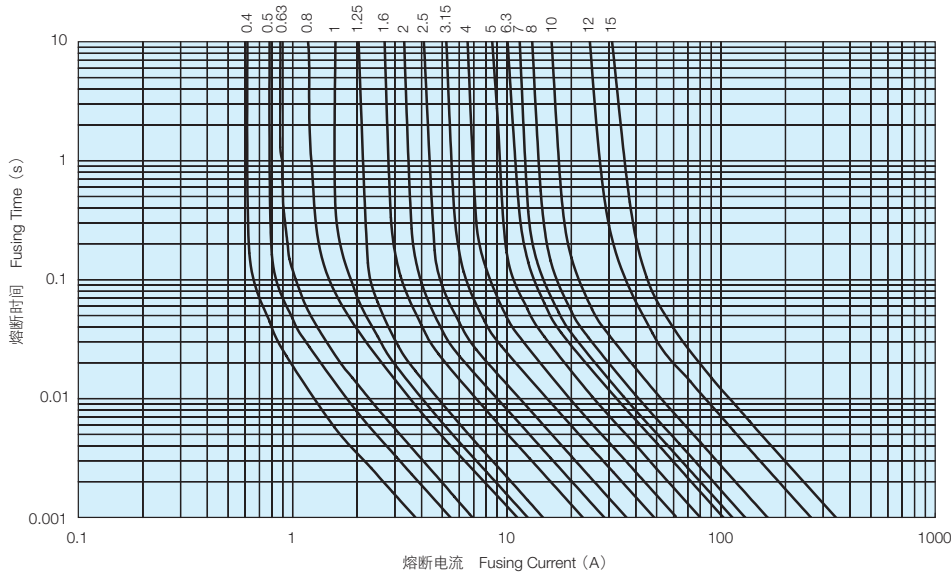

■ 性能 Performance

试验项目 Test Items	标准值 Performance Requirements ΔR±%		试验方法 Test Methods
	保证值 Limit	代表值 Typical	
熔断特性 Fusing characteristics	规定时间内熔断后的绝缘电阻在0.2MΩ以下。 Within specified time. No restrike	—	测定当通过额定电流的160%和200%的电流时所需的熔断时间。 Fusing time measured under rated current × 160% and × 200%.
表面温度上升 Surface Temp. Rise	温度上升140°C以下 (电气安全法) Max. Temp. Rise 140°C (For PSE)	—	通过额定电流值的115%的电流时，箱体的表面温度。 Surface Temp. should be measured by Rated current × 115%.
	温度上升75°C以下 (UL) Max. Temp. Rise 75°C (For UL)	—	通过额定电流时，箱体的表面温度。 Surface Temp. should be measured by Rated current × 100%.
电极强度 Bending test	应当没有电极剥离、导通断线等异常。 No mechanical damages.	—	支持点间隔90mm，弯曲宽度3mm，一次。 Distance between holding points 90mm, bending width 3mm, 1time.
耐焊接热 Resistance to soldering heat	10	3	260°C±5°C, 10s±0.5s
焊接性 Solderability	95%以上为新的焊接覆盖。 95% coverage min.	—	235°C±5°C, 3s±0.5s
通电寿命 Load life	10	5	70°C±2°C, 1000h, 额定电流×70%, 1.5小时ON/0.5小时OFF的周期。 Rated current×70%, 1.5h ON/0.5h OFF cycle
耐湿通电寿命 Load life moisture	10	5	40°C±2°C, 90%~95%RH, 1000h, 额定电流×70%, 1.5小时ON/0.5小时OFF的周期。 Rated current×70%, 1.5h ON/0.5h OFF cycle
温度突变 Rapid change of temperature	10	5	-55°C (30min) / +125°C (30min) 100 cycles

■ 使用注意事项 Precautions for Use

- 关于产品的保管、使用，不要在凝露、有害气体 (H₂S, SO₂, HC l 气体)、灰尘的环境。否则有可能降低产品的钎焊性，使其发生断线。
- 本产品由于受温度的影响，使用前请确认安装产品后，温度升高值在50度以下 (含50度)，及异常电流时，电路阻断评价。
- 选定保险丝时，请与本目录内的「保险丝的使用注意事项」一起确认。
- Store and use CCF products in dust-free room avoiding dew condensation, corrosive gas (H₂S, SO₂, HC l gas), etc. Otherwise the products are more likely to have lower solderability and fusing.
- High temperature affects on the product's performances. After mounting the products on your applications, be sure that the maximum temperature rise is 50 degrees or below and that if the circuit is interrupted or not under abnormal current.
- When you select fuse product, please make sure to confirm "Precautions for Use of Fusing Components" in this catalogue and ask KOA sales.

本样本册中记载的产品规格如有变更，恕不一一奉告。订购及使用之前，请仔细确认规格表的内容。

用于车载设备、医疗设备、航空设备以及其它涉及人身安全、或可能引起重大损失的设备上时，请务必先与我公司联系。这些产品在这类用途中出现故障或失灵可能导致人身事故或严重损坏。

Specifications given herein may be changed at any time without prior notice. Please confirm technical specifications before you order and/or use.

Contact our sales representatives before you use our products for applications including automobiles, medical equipment and aerospace equipment.

Malfunction or failure of the products in such applications may cause loss of human life or serious damage.