

## WU73 长边电极矩形低电阻片式电阻器 Wide Terminal Type Flat Low Chip Resistors

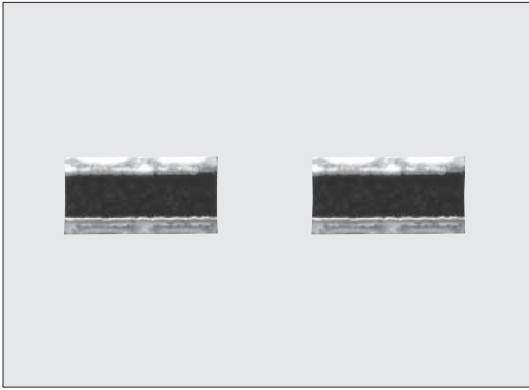

外观颜色: 黑色 Coating color: Black

### ■ 结构图 Construction

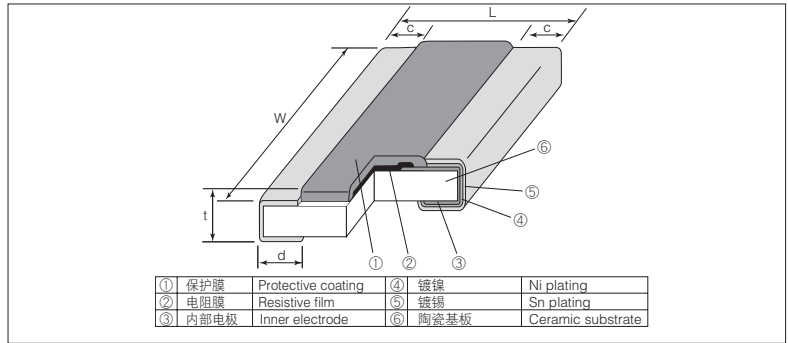

### ■ 特点 Features

- 长边电极片状电阻器。
- 是阻值允许偏差±1%、电阻温度系数±100×10<sup>-6</sup>/K的高可靠性、高性能产品。
- 对应回流焊、波峰焊。
- 符合欧盟RoHS。电极、电阻膜层、玻璃中所含的铅玻璃不适用欧盟RoHS指令。
- AEC-Q200相关数据已取得。
- Flat chip resistors of wide terminal type.
- High reliability and performance with T.C.R. ±100×10<sup>-6</sup>/K, resistance tolerance ±1%.
- Suitable for flow and reflow solderings.
- Products meet EU-RoHS requirements. EU-RoHS regulation is not intended for Pb-glass contained in Electrode, resistor element and glass.
- AEC-Q200 qualified.

### ■ 外形尺寸 Dimensions

型号 Type (Inch Size Code)	尺寸 Dimensions (mm)					Weight (g) (1000pcs)
	L	W	c	d	t	
2B (0612)	1.6±0.15	3.2 <sup>+0.1</sup> <sub>-0.3</sub>	0.4±0.2	0.45±0.15	0.6±0.1	12.0

### ■ 品名构成 Type Designation

实例 Example

WU73	2B	T	TD	10L0	F
品种 Product Code	额定功率 Power Rating	端子表面材质 Terminal Surface Material	二次加工 Taping	公称电阻值*1 Nominal Resistance	阻值允许偏差 Resistance Tolerance
WU73	2B:1W	T: Sn	TD: 4mm pitch punch paper BK: Bulk	4 digits Ex. 10L0: 10mΩ R100: 100mΩ	F: ±1%

※1

电阻值范围 (Ω) Resistance Value	4位显示 4 digits
10m~75m	10L0~75L0
0.1	R100

欲知关于此产品含有的环境负荷物质详情(除EU-RoHS以外), 请与我们联系。  
编带细节参照卷末附录C。  
Contact us when you have control request for environmental hazardous material other than the substance specified by EU-RoHS.  
For further information on taping, please refer to APPENDIX C on the back pages.

### ■ 用途 Applications

- 电源电路、ECU及车载载感器。
- Power supply, ECU etc.

### ■ 参考标准 Reference Standards

IEC 60115-8  
JIS C 5201-8  
EIAJ RC-2134C

### ■ 额定值 Ratings

型号 Type	额定功率 Power Rating	电阻温度系数 T.C.R. (×10 <sup>-6</sup> /K)	电阻值范围*2 Resistance Range (Ω)	阻值允许偏差 Resistance Tolerance	额定环境温度 Rated Ambient Temp.	额定端子部温度 Rated Terminal Part Temp.	使用温度范围 Operating Temp. Range	编带和包装数/卷 Taping & Q'ty/Reel (pcs)
WU73 2B	1W	±150	10m	F: ±1%	70℃	105℃	-55℃~155℃	5,000
		±100	15m、20m、25m、30m 50m、75m、100m					

额定电压是√额定功率×公称电阻值所算出的值。

Rated voltage = √Power Rating × Resistance value

※2 有关其他电阻值, 请与我们联系。

※2 Please ask about other resistance.

## ■ 负荷减轻特性曲线 Derating Curve

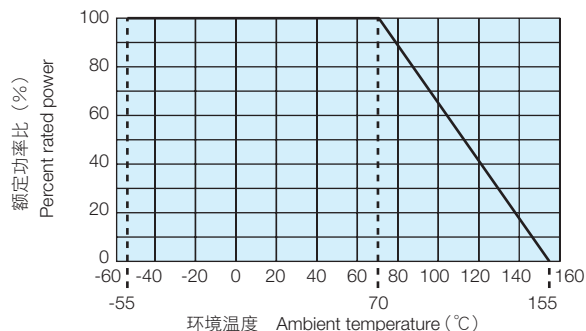

在环境温度70℃以上使用时，应按照上图负荷减轻特性曲线，减小额定功率。  
For resistors operated at an ambient temperature of 70°C or above, a power rating shall be derated in accordance with the derating curve.

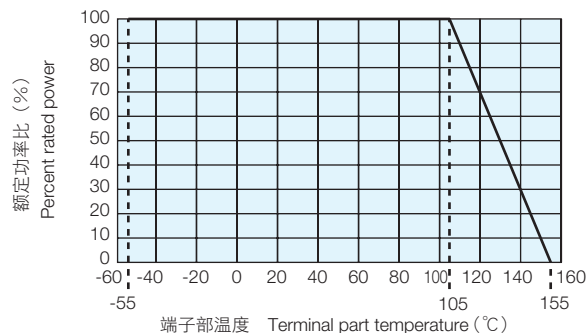

超过上述端子部温度使用时，请根据负荷减轻特性曲线减小额定功率后使用。  
※有关使用方法，请参照卷首的“端子部温度负荷减轻特性曲线的说明”。  
For resistors operated terminal part temperature of described for each size or above, a power rating shall be derated in accordance with derating curve.  
※Please refer to "Introduction of the derating curves based on the terminal part temperature" on the beginning of our catalog before use.

## ■ 性能 Performance

试验项目 Test Items	标准值 Performance Requirements $\Delta R \pm (\% + 0.005 \Omega)$		试验方法 Test Methods
	保证值 Limit	代表值 Typical	
电阻值 Resistance	在规定的允许偏差内 Within specified tolerance	—	25°C
电阻温度系数 T.C.R.	在规定值以内 Within specified T.C.R.	—	+25°C/-55°C and +25°C/+125°C
过载(短时间) Overload (Short time)	2	0.2	额定电压×2倍施加5秒钟 Rated voltage×2 for 5s
耐焊接热 Resistance to soldering heat	1	0.2	260°C±5°C, 10s±1s
端子强度 Bending test	1	0.1	挠曲强度:保持点间距90mm, 挠曲一次, 弯曲5mm Holding point 90mm, Bending 1time. Bending 5mm
温度突变 Rapid change of temperature	2	0.3	-55°C (30min.)/+125°C (30min.) 1000 cycles
耐湿负荷 Moisture resistance	2	0.1	40°C±2°C, 90~95%RH, 1000h 1.5小时ON、0.5小时OFF的周期 1.5h ON/0.5h OFF cycle
在70°C时的耐久性 Endurance at 70°C	2	0.2	70°C±2°C, 1000h 1.5小时ON、0.5小时OFF的周期 1.5h ON/0.5h OFF cycle
高温放置 High temperature exposure	1	0.1	+155°C, 1000h

## ■ 使用注意事项 Precautions for Use

- 片状电阻器的基材是氧化铝，由于和安装基板的热膨胀系数不同，在反复施加热循环等热应力时，结合部的焊锡（焊接部）有时会发生龟裂。由于WU73系列本身的发热量很大，如果环境温度反复发生很大的变动，并且载荷反复进行ON/OFF，则需要注意龟裂的发生。因热应力而发生的龟裂，取决于所安装的焊盘的大小、焊锡量、安装基板的散热性等，因此在环境温度有很大的变化或载荷ON/OFF的条件下使用时，请充分注意以进行设计。
- 对于50mΩ或以下的电阻值，焊接后的电阻值可能会根据焊盘图案的大小或焊锡量而变化。对设备进行设计时，请先确认电阻值下降、上升所造成的影响。
- The substrate of chip resistors is alumina. Cracks may occur at the connection of solder (solder fillet portion) due to the difference of the coefficient of thermal expansion from a mounting board when heat stress like heat cycle, etc. are repeatedly given to them. Care should be taken to the occurrence of the cracks when the change in ambient temperature or ON/OFF of load is repeated, especially when WU73 which have self-heating. The occurrence of the crack by heat stress may be influenced by the size of a pad, solder volume, heat radiation of mounting board etc., so please pay careful attention to designing when a big change in ambient temperature and conditions for use like ON/OFF of load can be assumed.
- In the resistance values of 50mΩ or under, the resistance value after soldering may change depending on the size of pad pattern or solder amount. Make sure the effect of decline/increase of resistance value before designing.