

DISCHARGE PATH RESISTOR

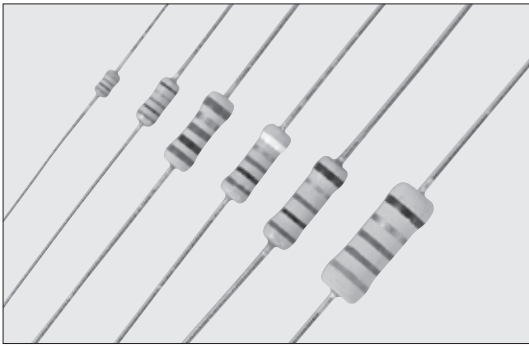

RCR 塗装絶縁形耐サージ固定抵抗器 Coat-Insulated Fixed Anti Surge Resistors



外表色：ブルーグレー Coating color : Blue gray
表示：RCR16以外…4色線カラーコード+識別カラーコード^{※1}
RCR16…4色線カラーコード
Marking : Excluding RCR16…4 line color codes+5th color code^{※1}
RCR16…4 line color codes
※1 RCR50+, RCR50EN (1MΩ~12MΩ) : 緑, RCR60 : 白, その他 : 黒
※1 RCR50+, RCR50EN (1MΩ~12MΩ) : Green, RCR60 : White, Others : Black
F級品のカラーコードにつきましては納入仕様書で内容をご確認ください。
Please confirm contents on technical specifications about the color code of F grade product.

■構造図 Construction

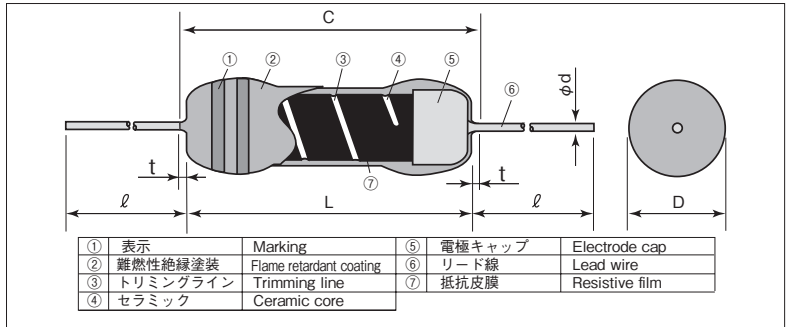

■外形寸法 Dimensions

形名 Type	寸法 Dimensions (mm)					重量 (g) (1000pcs)
	L	C Max.	t Max.	D	d(Nominal)	
RCR16	3.2±0.2	3.4	—	1.7 ^{+0.1} _{-0.1}	0.45	150
RCR25	6.3±0.5	7.1	—	2.5±0.5	0.6	240
RCR25EN						
RCR50 (+)	9.5±1.0	—	3.0	3.5±0.4	0.7	520
RCR50EN						
RCR60	9.5 ^{+1.0} _{-1.0}	—	3.0	3.5±0.4	0.7	520
RCR75	12.0±1.0	—	3.0	4.0±0.5	0.8	800
RCR100	15.5±1.0	—	3.0	6.0 ^{+1.0} _{-1.0}	0.8	1400

※2 テーピング及びフォーミングによってリード寸法が異なります。
※2 Lead length changes depending on taping and forming type.

■特長 Features

- 耐サージ特性に優れた抵抗器です。
- 高抵抗域まで耐湿性が安定した特性です。
- RCR50+ (1MΩ~12MΩ)、RCR50EN (1MΩ~12MΩ)、RCR60 (1MΩ~12MΩ) はUL1676及びc-UL (CSA-C22.2 No.1-M94) 放電抵抗器規格認定品です。
- RCR25EN (100kΩ~33MΩ)、RCR50EN (100kΩ~33MΩ) 及びRCR60 (100kΩ~56MΩ) はEN60065 14.1項 安全規格認定品です。
- 欧州RoHS対応品です。抵抗に含まれる鉛ガラスは欧州RoHS適用除外です。
- 面実装フォーミングによる自動実装が可能です。
- Excellent anti-surge characteristics.
- Stable characteristics of moisture resistance up to high resistance range.
- RCR50+ (1MΩ~12MΩ)、RCR50EN (1MΩ~12MΩ) and RCR60 (1MΩ~12MΩ) are conductive-path and Discharge-path Resistors recognized by UL1676 and c-UL (CSA-C22.2 No.1-M94).
- RCR25EN (100kΩ~33MΩ)、RCR50EN (100kΩ~33MΩ) and RCR60 (100kΩ~56MΩ) is approved by EN60065 14.1 safety.
- Products meet EU-RoHS requirement. EU-RoHS regulation is not intended for Pb-glass contained in resistor element.
- Automatic mounting machine is applicable by surface mounted device style lead forming.

■品名構成 Type Designation

例 Example

RCR	50	EN	C	T52	A	106	J
品名 Product Code	定格電力 Power Rating	安全規格記号 Safety Approvals Marking	端子表面材質 Terminal Surface Material	二次加工 Taping & Forming	包装 Packaging Forming	公称抵抗値 Nominal Resistance	抵抗値許容差 Resistance Tolerance
	16:0.25W 25:0.25W 50:0.5W 60:1W 75:2W 100:3W	+ : RCR50+ EN : RCR25EN, RCR50EN 空欄 : それ以外 Nil : Others	C:SnCu	下参照 See table below	A:アモバック A:AMMO R:リール R:REEL TEB-TEG:Plastic embossed (N forming) 空欄:ボックス Nil:BOX	F:4 digits J:3 digits	F:±1% J:±5%

環境負荷物質含有についてEU-RoHS以外の物質に対するご要求がある場合にはお問合せください。
テーピング及びフォーミングの詳細については巻末のAPPENDIX Cを参照してください。
Contact us when you have control request for environmental hazardous material other than the substance specified by EU-RoHS.
For further information on taping and forming, please refer to APPENDIX C on the back pages.

■用途 Applications

- TV、TVs
- 複写機 Copy machines
- LBP
- VTRs
- スイッチング電源 Switching power supplies
- ACアダプタ AC adapters

■取得規格 Approvals Awarded

形名 Type	UL1676 & c-UL (CSA-C22.2 No.1-M94)	EN60065 14.1項	
		Test a	Test b
RCR25EN	○	○	○
RCR50+	○	○	○
RCR50EN	○	○	○
RCR60	○	○	○

■定格 Ratings

形名 Type	定格電力 Power Rating	抵抗値範囲 (Ω) Resistance Range		最高使用電圧 Max. Working Voltage	最高過負荷電圧 Max. Overload Voltage	耐電圧 Dielectric Withstanding Voltage	テーピングと包装数/アモ包装 Taping & Q'ty/AMMO (pcs)			
		F:±1% (E24-E96)	J:±5% (E24)				T26	T52	T521	T631
RCR16	0.25W	100k~5.1M	100k~5.1M	500V	1000V	300V	5000	3000	—	—
RCR25		100k~9.1M	100k~33M	D.C. 1600V	D.C. 2000V	700V	2000	2000	—	—
RCR25EN		100k~9.1M	100k~33M	A.C. 1150V	A.C. 1500V	700V	2000	2000	—	—
RCR50	0.5W	3.3Ω~910k	3.3~910k	2000V	2500V	700V	—	2000	—	—
RCR50+		100k~9.1M	13M~33M				—	2000	—	—
RCR50EN		100k~9.1M	100k~33M				—	2000	—	—
RCR60	1W	100k~9.1M	100k~56M	4000V	5000V	700V	—	2000	—	—
RCR75	2W	100k~9.1M	100k~100M	5000V	5000V	700V	—	1000	—	—
RCR100	3W	100k~9.1M	100k~51M	5000V	5000V	1000V	—	—	500	1000

定格周囲温度 Rated Ambient Temperature : +70℃
使用温度範囲 Operating Temperature Range : -55℃~+155℃

定格電圧は√定格電力×公称抵抗値による算出値、又は表中の最高使用電圧のいずれか小さい値が定格電圧となります。

Rated voltage=√Power Rating×Resistance value or Max. working voltage, whichever is lower.

本カタログに掲載の仕様は予告なく変更する場合があります。ご注文およびご使用前に納入仕様書で内容をご確認ください。
車載機器、医療機器、航空機器など人命に関わったり、あるいは甚大な損害を引き起こす可能性のある機器へのご使用を検討される場合には、必ず事前にご相談ください。
Specifications given herein may be changed at any time without prior notice. Please confirm technical specifications before you order and/or use.
Contact our sales representatives before you use our products for applications including automobiles, medical equipment and aerospace equipment.
Malfunction or failure of the products in such applications may cause loss of human life or serious damage.

高電圧用抵抗器
High Voltage Type Resistors

■ 負荷軽減曲線 Derating Curve

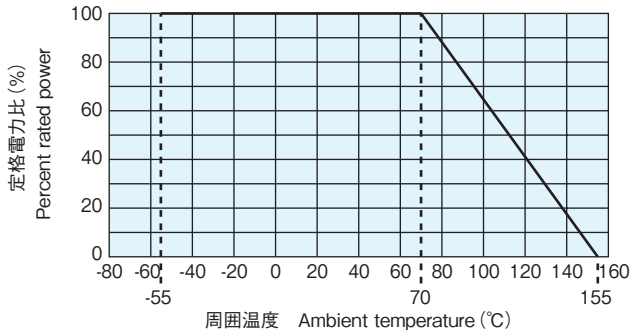

周囲温度70℃以上で使用される場合は、上図負荷軽減曲線に従って、定格電力を軽減して御使用ください。

For resistors operated at an ambient temperature of 70℃ or above, a power rating shall be derated in accordance with the above derating curve.

■ サージ負荷に関する注意事項 Notice on Surge Load

本抵抗器のサージ耐圧につきまして、下記4点が耐サージ特性のサージ耐圧で表す条件に比し、著しい過負荷となる場合保証しかねますので、予め当社にお問い合わせください。Surge withstanding load voltage for the resistors cannot be guarantee when the undermentioned 4 items get to a remarkable overload in comparison with the conditions shown by surge withstanding voltage in Anti-surge characteristics. You are kind by requested to contact to us in advance if such a case is anticipated.

- (1) 印加されるピーク電圧
Peak voltage to be applied
- (2) パルス幅
Pulse width
- (3) 抵抗器周辺の絶縁保護条件
Conditions of protecting insulation around the resistor
- (4) 接近導電物の状況
Situation of proximity conductivity object

例えば下図の様に、抵抗器本体より約5mm未満の位置に金属線があると、10kVのサージ負荷により放電が発生し、外装が破壊する場合があります。

As the fig. below for instance when a metal wire is placed at less than 5mm away from the resistor body, there is such a case that causes an electric discharge by a surge load 10kV and then destroys the outer coating.

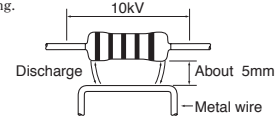

■ 性能 Performance

試験項目 Test Items	規格値 Performance Requirements $\Delta R \pm (\% + 0.05 \Omega)$		試験方法 Test Methods																														
	保証値 Limit	代表値 Typical																															
抵抗値 Resistance	規定の許容差内 Within specified	—	測定箇所は本体から10mm±1mmとする Measuring points are at 10mm±1mm from the end cap.																														
抵抗温度係数 T.C.R.	<table border="1"> <thead> <tr> <th>形名 Type</th> <th>抵抗温度係数 T.C.R.</th> <th>抵抗値範囲 Resistance Range</th> </tr> </thead> <tbody> <tr><td>RCR16</td><td>$\pm 200 \times 10^{-4}/K$</td><td>100kΩ~5.1MΩ</td></tr> <tr><td>RCR25</td><td>$\pm 350 \times 10^{-4}/K$</td><td>100kΩ~33MΩ</td></tr> <tr><td>RCR25EN</td><td>$\pm 350 \times 10^{-4}/K$</td><td>100kΩ~33MΩ</td></tr> <tr><td>RCR50(+)</td><td>$\pm 500 \times 10^{-4}/K$</td><td>3.3Ω~91kΩ</td></tr> <tr><td>RCR50(+)</td><td>$\pm 350 \times 10^{-4}/K$</td><td>100kΩ~33MΩ</td></tr> <tr><td>RCR50EN</td><td>$\pm 350 \times 10^{-4}/K$</td><td>100kΩ~33MΩ</td></tr> <tr><td>RCR60</td><td>$\pm 350 \times 10^{-4}/K$</td><td>100kΩ~56MΩ</td></tr> <tr><td>RCR75</td><td>$\pm 350 \times 10^{-4}/K$</td><td>100kΩ~100MΩ</td></tr> <tr><td>RCR100</td><td>$\pm 200 \times 10^{-4}/K$</td><td>100kΩ~51MΩ</td></tr> </tbody> </table>	形名 Type	抵抗温度係数 T.C.R.	抵抗値範囲 Resistance Range	RCR16	$\pm 200 \times 10^{-4}/K$	100k Ω ~5.1M Ω	RCR25	$\pm 350 \times 10^{-4}/K$	100k Ω ~33M Ω	RCR25EN	$\pm 350 \times 10^{-4}/K$	100k Ω ~33M Ω	RCR50(+)	$\pm 500 \times 10^{-4}/K$	3.3 Ω ~91k Ω	RCR50(+)	$\pm 350 \times 10^{-4}/K$	100k Ω ~33M Ω	RCR50EN	$\pm 350 \times 10^{-4}/K$	100k Ω ~33M Ω	RCR60	$\pm 350 \times 10^{-4}/K$	100k Ω ~56M Ω	RCR75	$\pm 350 \times 10^{-4}/K$	100k Ω ~100M Ω	RCR100	$\pm 200 \times 10^{-4}/K$	100k Ω ~51M Ω	—	室温/100℃ up Room temperature+100℃
形名 Type	抵抗温度係数 T.C.R.	抵抗値範囲 Resistance Range																															
RCR16	$\pm 200 \times 10^{-4}/K$	100k Ω ~5.1M Ω																															
RCR25	$\pm 350 \times 10^{-4}/K$	100k Ω ~33M Ω																															
RCR25EN	$\pm 350 \times 10^{-4}/K$	100k Ω ~33M Ω																															
RCR50(+)	$\pm 500 \times 10^{-4}/K$	3.3 Ω ~91k Ω																															
RCR50(+)	$\pm 350 \times 10^{-4}/K$	100k Ω ~33M Ω																															
RCR50EN	$\pm 350 \times 10^{-4}/K$	100k Ω ~33M Ω																															
RCR60	$\pm 350 \times 10^{-4}/K$	100k Ω ~56M Ω																															
RCR75	$\pm 350 \times 10^{-4}/K$	100k Ω ~100M Ω																															
RCR100	$\pm 200 \times 10^{-4}/K$	100k Ω ~51M Ω																															
過負荷(短時間) Overload (Short time)	1	0.5	定格電圧×2.5倍又は最高過負荷電圧の低い方を5秒印加 Rated voltage×2.5 or Max. overload vol., whichever is lower, for 5s.																														
はんだ耐熱性 Resistance to soldering heat	1	0.5	260℃±5℃, 10s±1s or 350℃±10℃, 3.5s±0.5s																														
端子強度 Terminal strength	リード線の外れ、端子のユルミのないこと。 No lead-coming off and loose terminals	—	Twist 360°, 5 times																														
温度急変 Rapid change of temperature	1	0.5	-55℃ (30min.) / +155℃ (30min.) 5 cycles																														
耐湿負荷 Moisture resistance	5	2.5	40℃±2℃, 90%~95%RH, 1000h 1.5時間 ON/0.5時間 OFFの周期 1.5h ON/0.5h OFF cycle RCR16, 25, 50(+), 60: W RCR75, 100: W×0.1																														
70℃での耐久性 Endurance at 70℃	5	2.5	70℃±2℃, 1000h, Rv 1.5時間 ON/0.5時間 OFFの周期 1.5h ON/0.5h OFF cycle																														
耐溶剤性 Resistance to solvent	外観に異常がなく、表示は容易に判読できること。 No abnormality in appearance. Marking shall be easily legible.	—	インソプロピルアルコールの超音波洗浄を2分間行う Ultrasonic washing with Isopropyl alcohol for 2 min. 出力Power: 0.3W/cm ² , 周波数f: 28kHz, 温度Temp: 35℃±5℃																														
耐サージ特性 Anti-surge characteristics	10	2.5	放電試験: 2kV~10kVに充電した0.01 μ Fコンデンサーから5秒間に1回以下の割合で10回放電を加える。 Discharge test: 2kV~10kV 0.01 μ F capacitor discharge pulse 10 times. (1pulse/5sec. max.) <table border="1"> <thead> <tr> <th>Type</th> <th>RCR16</th> <th>RCR25・RCR25EN</th> <th>RCR50・RCR50+</th> <th>RCR50EN</th> <th>RCR60</th> <th>RCR75</th> <th>RCR100</th> </tr> </thead> <tbody> <tr> <td rowspan="4">印加電圧 Applied voltage</td> <td rowspan="4">2kV</td> <td rowspan="4">3kV</td> <td>3.3Ω~6.2Ω: 10kV</td> <td rowspan="4">10kV</td> <td rowspan="4">10kV</td> <td rowspan="4">10kV</td> <td rowspan="4">10kV</td> </tr> <tr><td>6.8Ω~10Ω: 7kV</td></tr> <tr><td>11Ω~9.1kΩ: 5kV</td></tr> <tr><td>10kΩ~91kΩ: 7kV</td></tr> <tr> <td></td> <td></td> <td></td> <td>100kΩ~33MΩ: 10kV</td> <td></td> <td></td> <td></td> <td></td> </tr> </tbody> </table>	Type	RCR16	RCR25・RCR25EN	RCR50・RCR50+	RCR50EN	RCR60	RCR75	RCR100	印加電圧 Applied voltage	2kV	3kV	3.3 Ω ~6.2 Ω : 10kV	10kV	10kV	10kV	10kV	6.8 Ω ~10 Ω : 7kV	11 Ω ~9.1k Ω : 5kV	10k Ω ~91k Ω : 7kV				100k Ω ~33M Ω : 10kV							
Type	RCR16	RCR25・RCR25EN	RCR50・RCR50+	RCR50EN	RCR60	RCR75	RCR100																										
印加電圧 Applied voltage	2kV	3kV	3.3 Ω ~6.2 Ω : 10kV	10kV	10kV	10kV	10kV																										
			6.8 Ω ~10 Ω : 7kV																														
			11 Ω ~9.1k Ω : 5kV																														
			10k Ω ~91k Ω : 7kV																														
			100k Ω ~33M Ω : 10kV																														
EN60065試験 (RCR50EN, RCR60限定) EN60065 test (RCR50EN, RCR60 Only)	20	—	放電試験: 10kVに充電した1000pFコンデンサーから5秒間に1回以下の割合で50回放電を加える。 Discharge test: 10kV 1000pF capacitor discharge pulse 50 times. (1pulse/5sec. max.)																														

■ 使用上の注意 Precautions for Use

- 外装塗装が難燃性特殊塗料の為、外部衝撃に比較的弱いので取り扱いにご注意ください。洗浄は最小限にしてください。洗浄直後は多少塗装膜が弱くなりますので、十分に乾燥するまで塗装膜に外力を加えないでください。乾燥後、元の強度に戻りますので、洗浄後約20分間は抵抗器の塗装膜に外力が加わらない様に配慮ください。特に基板の積み重ね等は、行わないでください。
- 高抵抗値の製品は、表面漏れ電流を防ぐ為に直接手で触れないようにしてください。
- 近接に導電物がある場合は、コロナの発生や放電短絡の可能性があるので、ご相談ください。
- 高温・多湿・汚れの付着等の悪環境下、または樹脂モールド等してご使用になることは、抵抗値変化の原因となりますのでご遠慮ください。
- RCR50 100k Ω 未満は抵抗皮膜が異なるため、著しい湿度環境やイオン性物質に汚染されると特性が低下する恐れがありますので予め当社にお問い合わせください。
- Be careful to handle these resistors because outer coatings are comparatively weak to outer shock due to flameproof special coats. Please wash them to a minimum. No external force is given to the coating films until they are well dried because the coating films become weaker right after washing. The original strength will be returned after they are dried, so please pay attention not to apply any external force onto the coating film of resistors for 20 minutes after drying. Especially no PC boards shall be piled up.
- Do not touch the resistors with high-resistance value by hand to prevent surface-leakage current.
- Consult with us when there are electric conductors near to because it may cause corona and short-circuit by discharge.
- Please do not apply resistors under such bad conditions as high temperature, high humidity, and foul adhesion, or with resin molding, because it may cause the change of resistance value.
- The resistance film of less than RCR50 100k Ω is different. Therefore, the characteristic might decrease when it is polluted by a remarkable moisture environment and the ionic material so inquire of our company beforehand, please.