

## U37L 系列

- 大型电容器
- 螺丝端子型
- 通用型 U37等级
- 高纹波电流
- 额定电压350~500V<sub>dc</sub>
- 符合RoHS
- 保证寿命 85℃ 10,000小时
- 视使用条件, 耐用寿命最长为175,000小时。



U37L系列是为高可靠性变频器设计的长寿命型螺丝端子U37等级的产品, 实现了高纹波电流化和长寿命化。保证寿命为10,000小时的U37L系列, 在环境温度+40℃、叠加2倍额定纹波电流条件下, 耐用寿命最长175,000小时。此系列电容拥有各种耐高电流的英制和公制螺纹端子。固定方法可选择三脚绑带安装或者底部螺栓安装。

## 特性概要

- 螺丝端子: 有高尺寸或低尺寸的端子种类, 英制和公制螺纹
- 容量范围: 1,500~18,000µF
- 电压范围: 350~500V<sub>dc</sub>
- 温度范围: -40℃~+85℃
- 漏电流: 以0.02CV(µA)或5mA中较小值为准(在25℃下放置5分钟后)
- 尺寸(φD×L): D=50mm(2.000inch)~89mm(3.500inch)、L=92mm(3.625inch)~219mm(8.625inch)
- 保证寿命: 10,000小时(85℃, 叠加额定纹波电流)

## U37L系列

U37L 规格表 - 螺丝端子型

项目	性能																																					
工作温度范围	-40~+85℃																																					
额定电压范围	350~500VDC																																					
静电容量范围	1,500~18,000 μF (25℃, 120Hz)																																					
静电容量容许差	±20%(M) (25℃, 120Hz)																																					
漏电流	I=0.02CV(μA)或5mA中任意一个较小值 I: 漏电流(μA), C: 静电容量(μF) V: 额定电压(V) (在25℃下放置5分钟后)																																					
额定纹波电流系数	环境温度系数(℃)																																					
	45℃	65℃																																				
	2.82	1.73																																				
频率系数(Hz)		85℃																																				
DC额定电压	50Hz	120Hz	300Hz	1kHz	3kHz	10kHz																																
350-500V	0.80	1.00	1.20	1.30	1.40	1.41																																
在指定温度和频率下的最大额定纹波电流, 请选用相应的系数。																																						
耐久性	在85℃环境中, 不超过额定电压范围下叠加额定纹波电流, 连续加载10,000小时后, 待温度恢复到25℃进行测量, 应满足以下要求。 静电容量变化率 : ≤初始值的20% ESR : ≤初始规格值的200% 漏电流 : ≤初始规格值																																					
耐用寿命	施加特定的电压和纹波电流, 寿命和环境温度的关系如下。		静电容量变化率 : ≤初始值的30%																																			
	85℃	最大13,000小时	ESR : ≤初始规格值的300%																																			
	65℃	最大47,700小时	漏电流 : ≤初始规格值																																			
45℃	最大175,000小时																																					
高温无负荷特性	在85℃环境中, 无负荷放置500小时后, 待温度恢复到25℃后, 施加额定电压30分钟, 然后放置大于24小时不超过48小时后进行测量, 应满足以下要求。 静电容量变化率 : ≤初始值的20% ESR : ≤初始规格值的200% 漏电流 : ≤初始规格值																																					
耐振动性	10-50Hz正弦波形, 在三个轴方向施加10G的力, 每个轴施加力时间为2小时。																																					
最大紧固扭矩	<table border="1"> <thead> <tr> <th>端子代码</th> <th>HP</th> <th>HL</th> <th>CD</th> <th>CP</th> <th>CH</th> <th>CA</th> <th>CS</th> </tr> </thead> <tbody> <tr> <td>螺纹尺寸</td> <td>10-32 NF-2B</td> <td colspan="2">M5×0.8-6H</td> <td colspan="2">1/4-28 NF-2B</td> <td colspan="2">M6×1-6H</td> </tr> <tr> <td>3螺纹咬合</td> <td colspan="3">2.0 N·m(18.0 in·lb)</td> <td colspan="4">4.0 N·m(35.0 in·lb)</td> </tr> <tr> <td>6螺纹咬合</td> <td colspan="3">2.8 N·m(25.0 in·lb)</td> <td colspan="4">6.2 N·m(55.0 in·lb)</td> </tr> </tbody> </table>						端子代码	HP	HL	CD	CP	CH	CA	CS	螺纹尺寸	10-32 NF-2B	M5×0.8-6H		1/4-28 NF-2B		M6×1-6H		3螺纹咬合	2.0 N·m(18.0 in·lb)			4.0 N·m(35.0 in·lb)				6螺纹咬合	2.8 N·m(25.0 in·lb)			6.2 N·m(55.0 in·lb)			
端子代码	HP	HL	CD	CP	CH	CA	CS																															
螺纹尺寸	10-32 NF-2B	M5×0.8-6H		1/4-28 NF-2B		M6×1-6H																																
3螺纹咬合	2.0 N·m(18.0 in·lb)			4.0 N·m(35.0 in·lb)																																		
6螺纹咬合	2.8 N·m(25.0 in·lb)			6.2 N·m(55.0 in·lb)																																		
等效串联电感 (nH/1MHz)(参考值)	尺寸		端子代码																																			
			HP	HL	CD	CP	CH	CA	CS																													
	φ 50.8		—	—	不适用	不适用	不适用	不适用	不适用																													
	φ 63.5		—	—	—	—	—	—	—																													
	φ 76.2		30	30	25	20	25	20	25																													
φ 89.0		30	30	25	20	25	20	25																														
客户订制	可根据对应不同尺寸的CV值和端子类型为客户订制具体请和我司相关人员联络。																																					

# U37L 系列

## U37F 耐用寿命

耐用寿命：13,000小时 (85℃)

在不同环境温度下加载额定纹波电流，耐用寿命如图所示。

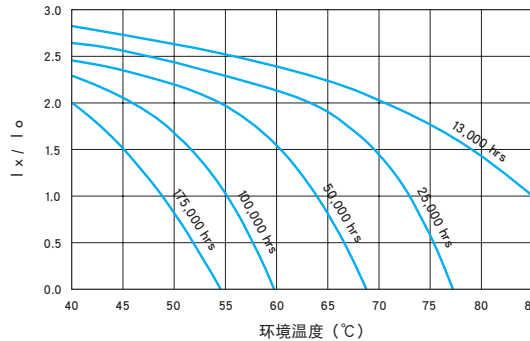

$I_o$ : 额定纹波电流 (Arms/85℃, 120Hz)  
 $I_x$ : 实际叠加纹波电流 (Arms/120Hz)

## 尺寸图-螺丝端子

大型电容器/螺丝端子型

单位：[mm(英寸)]

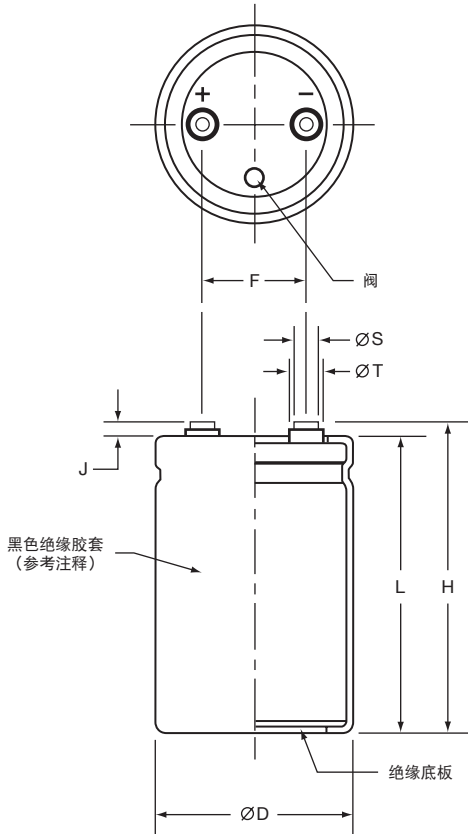

### 产品尺寸和包装数量

尺寸代码	φD	L	F	包装数量
CB7	+2.0(0.080)	±1.0(0.040)	±0.25(0.010)	49
CD0	50.8(2.000)	117(4.625)	22.2(0.875)	
D92	63.5(2.500)	92(3.625)	28.6(1.125)	20
DA5		105(4.125)		
DB7		117(4.625)		
DD0		130(5.125)		
DE3		143(5.625)		
E92	76.2(3.000)	92(3.625)	31.8(1.250)	16
EA5		105(4.125)		
EB7		117(4.625)		
EE3		143(5.625)		9
EJ1		181(7.125)		
EM9		219(8.625)		
F92	89.0(3.500)	92(3.625)	31.8(1.250)	5
FA5		105(4.125)		
FB7		117(4.625)		
FE3		143(5.625)		
FF5		155(6.125)		
FK0		190(7.500)		
FM9		219(8.625)		

注：在有些情况下，胶套颜色会因工作环境有轻微改变，但是不会影响产品性能。

### 端子尺寸规格

端子代码	铝壳尺寸		螺纹尺寸	最小螺纹深度	±0.5 (0.020)	±2.0 (0.080)	φS ±0.25 (0.010)	φT ±0.25 (0.010)
	φD 代码	φD mm (英寸)						
HP	C	50.8(2.000)	10-32NF-2B	9.5(0.375)	6.4(0.250)	L+J	8.0(0.313)	11.1(0.438)
HL	C	50.8(2.000)	M5×0.8-6H	9.5(0.375)	6.4(0.250)	L+J	8.0(0.313)	11.1(0.438)
CD	D-E	63.5-76.2(2.500-3.000)	M5×0.8-6H	8.5(0.335)	5.0(0.200)	L+J	13.0(0.512)	18.8(0.740)
CP	D-F	63.5-89.0(2.500-3.500)	1/4-28 NF-2B	8.7(0.344)	2.4(0.093)	L+J	17.5(0.689)	—
CH	D-F	63.5-89.0(2.500-3.500)	1/4-28 NF-2B	11.9(0.468)	6.4(0.250)	L+J	17.5(0.689)	—
CA	D-F	63.5-89.0(2.500-3.500)	M6×1-6H	8.7(0.344)	2.4(0.093)	L+J	17.5(0.689)	—
CS	D-F	63.5-89.0(2.500-3.500)	M6×1-6H	11.9(0.468)	6.4(0.250)	L+J	17.5(0.689)	—

安装配件是可选择的，请参考下一页配件说明。

# U37L系列

## 安装配件-螺丝端子

类型C：三脚绑带

单位：[mm(英寸)]

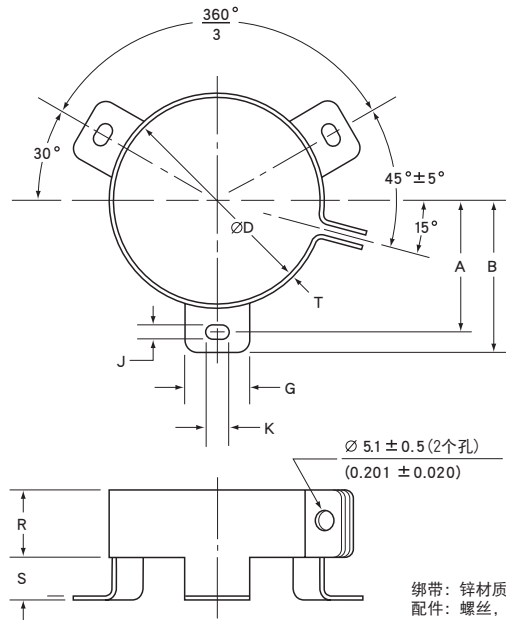

绑带：锌材质镀三价铬银  
配件：螺丝，垫圈和六角螺帽（含夹板）

类型C：绑带尺寸

安装代码	铝壳 $\phi D$	A $\pm 1.0(0.040)$	B $\pm 1.0(0.040)$	G $\pm 1.0(0.040)$	J $\pm 0.5(0.020)$	K $\pm 0.5(0.020)$	R $\pm 1.0(0.040)$	S $\pm 1.0(0.040)$	T $\pm 0.5(0.020)$
C	50.8(2.000)	31.8(1.250)	36.5(1.437)	13.3(0.524)	4.5(0.177)	7.1(0.280)	19.1(0.751)	9.5(0.374)	0.8(0.032)
C	63.5(2.500)	38.1(1.500)	42.9(1.689)	13.3(0.524)	4.5(0.177)	7.1(0.280)	19.1(0.751)	9.5(0.374)	0.8(0.032)
C	76.2(3.000)	44.5(1.750)	49.2(1.937)	13.3(0.524)	4.5(0.177)	7.1(0.280)	19.1(0.751)	9.5(0.374)	1.0(0.040)
C	89.0(3.500)	50.8(2.000)	56.5(2.224)	16.0(0.630)	4.5(0.177)	8.0(0.313)	21.0(0.827)	9.0(0.354)	1.0(0.040)

类型S：螺栓安装

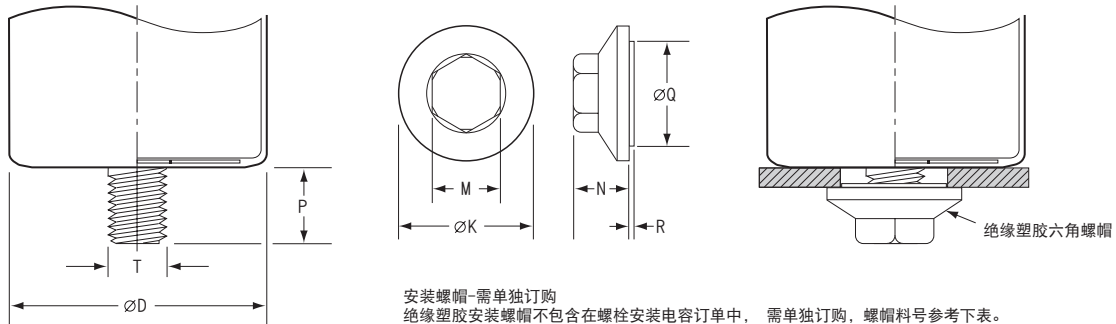

安装螺帽-需单独订购  
绝缘塑胶安装螺帽不包含在螺栓安装电容订单中，需单独订购，螺帽料号参考下表。

类型S：螺栓尺寸

安装代码	P $\pm 1.0(0.040)$	T螺纹尺寸
S	16.0(0.630)	M12

安装螺帽尺寸

料号	$\phi K$ $\pm 2.0(0.080)$	M $\pm 1.0(0.040)$	N $\pm 1.0(0.040)$	$\phi Q$ $\pm 1.0(0.040)$	R $\pm 1.0(0.040)$
50-8D	30.0(1.181)	19.0(0.748)	18.0(0.709)	22.0(0.866)	1.40(0.055)
50-8E	38.0(1.496)	19.0(0.748)	18.0(0.709)	30.0(1.181)	1.40(0.055)

# U37L系列

## U37L系列产品型号的表示方法

下订单时通常采用完整的18位编码。

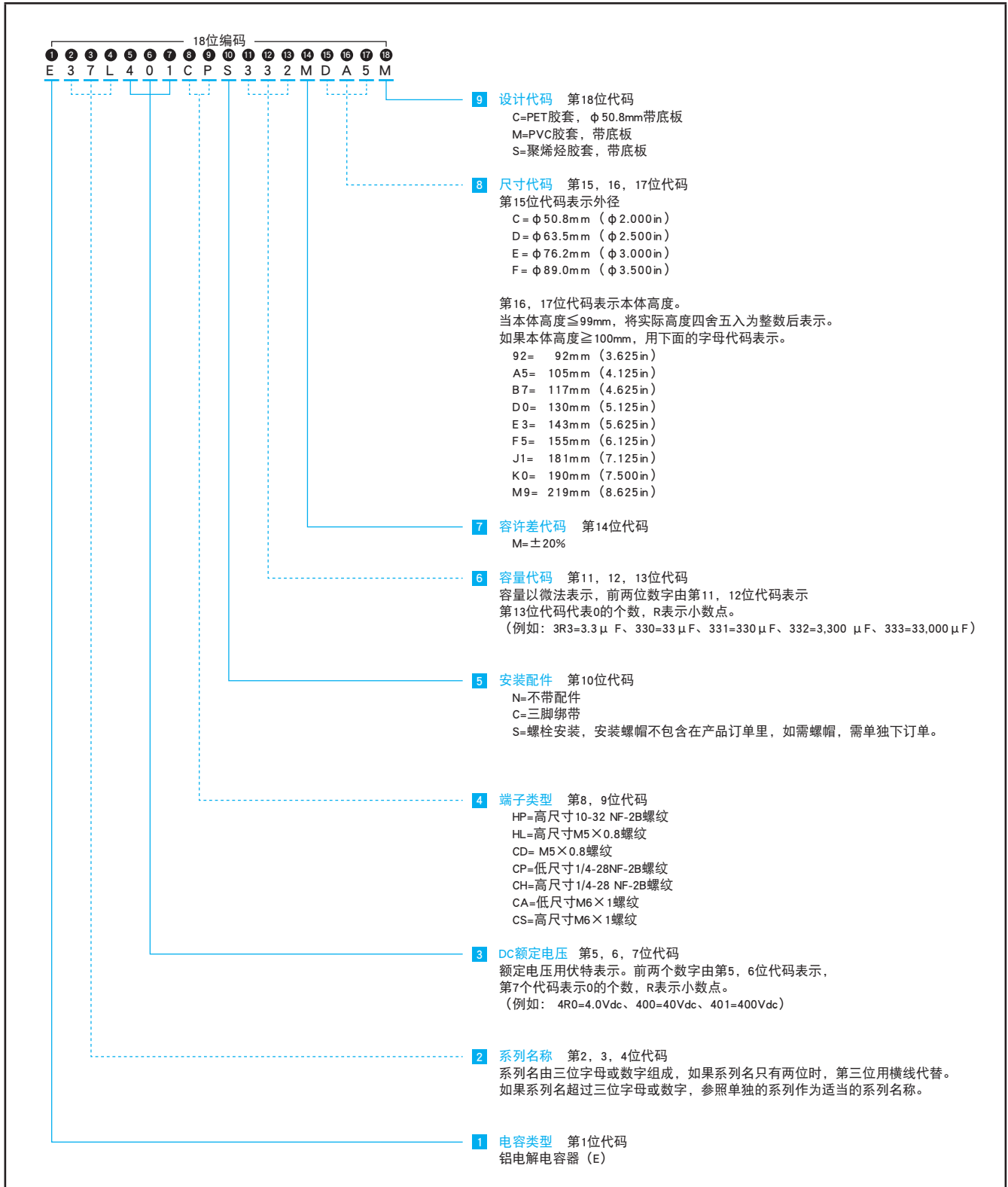

U37L系列

标准品一览表

额定电压 (WVDC)	容量 (μF)	产品型号 (注1)	尺寸 (注2) φD×L (mm)	尺寸代码	最大ESR(mΩ) 25℃,120Hz	额定纹波电流(A rms) 85℃		
						120Hz	300Hz	>3kHz
350 浪涌电压400	3,300	E37L351HPN332MCB7M	50×117	CB7	29	10.6	12.7	14.8
	3,300	E37L351HPN332MCD0M	50×130	CD0	29	11.0	13.1	15.3
	3,300	E37L351CPN332MD92M	63.5×92	D92	30	10.7	12.8	15.0
	3,900	E37L351CPN392MDA5M	63.5×105	DA5	26	12.2	14.6	17.0
	3,900	E37L351CPN392MDB7M	63.5×117	DB7	26	12.6	15.2	17.7
	4,700	E37L351CPN472MDD0M	63.5×130	DD0	21	14.4	17.3	20.2
	5,600	E37L351CPN562MDE3M	63.5×143	DE3	18	16.3	19.5	22.8
	4,700	E37L351CPN472ME92M	76.2×92	E92	22	13.9	16.7	19.5
	5,600	E37L351CPN562MEA5M	76.2×105	EA5	18	15.8	19.0	22.1
	6,800	E37L351CPN682MEB7M	76.2×117	EB7	15	18.1	21.7	25.4
	8,200	E37L351CPN822MEE3M	76.2×143	EE3	13	21.3	25.6	29.9
	12,000	E37L351CPN123MEJ1M	76.2×181	EJ1	9	28.2	33.9	39.5
	15,000	E37L351CPN153MEM9M	76.2×219	EM9	7	34.0	40.8	47.6
	6,800	E37L351CPN682MF92M	89×92	F92	15	18.3	22.0	25.6
	8,200	E37L351CPN822MFA5M	89×105	FA5	13	21.0	25.2	29.3
	8,200	E37L351CPN822MFB7M	89×117	FB7	13	21.8	26.1	30.5
	12,000	E37L351CPN123MFE3M	89×143	FE3	9	28.2	33.8	39.5
	12,000	E37L351CPN123MFF5M	89×155	FF5	9	29.0	34.8	40.6
15,000	E37L351CPN153MFK0M	89×190	FK0	7	35.0	42.0	49.1	
18,000	E37L351CPN183MFM9M	89×219	FM9	6	41.1	49.4	57.6	
400 浪涌电压450	2,700	E37L401HPN272MCB7M	50×117	CB7	35	9.5	11.5	13.4
	3,300	E37L401HPN332MCD0M	50×130	CD0	29	11.0	13.1	15.3
	2,700	E37L401CPN272MD92M	63.5×92	D92	37	9.7	11.6	13.6
	3,300	E37L401CPN332MDA5M	63.5×105	DA5	30	11.2	13.4	15.7
	3,900	E37L401CPN392MDB7M	63.5×117	DB7	26	12.6	15.2	17.7
	3,900	E37L401CPN392MDD0M	63.5×130	DD0	26	13.1	15.7	18.4
	4,700	E37L401CPN472MDE3M	63.5×143	DE3	21	14.9	17.9	20.9
	3,900	E37L401CPN392ME92M	76.2×92	E92	27	12.7	15.2	17.7
	4,700	E37L401CPN472MEA5M	76.2×105	EA5	22	14.5	17.4	20.3
	5,600	E37L401CPN562MEB7M	76.2×117	EB7	18	16.4	19.7	23.0
	6,800	E37L401CPN682MEE3M	76.2×143	EE3	15	19.4	23.3	27.2
	10,000	E37L401CPN103MEJ1M	76.2×181	EJ1	10	25.8	30.9	36.1
	12,000	E37L401CPN123MEM9M	76.2×219	EM9	9	30.4	36.5	42.6
	5,600	E37L401CPN562MF92M	89×92	F92	18	16.6	20.0	23.3
	6,800	E37L401CPN682MFA5M	89×105	FA5	15	19.1	22.9	26.7
	8,200	E37L401CPN822MFB7M	89×117	FB7	13	21.8	26.1	30.5
	10,000	E37L401CPN103MFE3M	89×143	FE3	10	25.7	30.9	36.0
	12,000	E37L401CPN123MFF5M	89×155	FF5	9	29.0	34.8	40.6
15,000	E37L401CPN153MFK0M	89×190	FK0	7	35.0	42.0	49.1	
18,000	E37L401CPN183MFM9M	89×219	FM9	6	40.6	48.7	56.8	
420 浪涌电压470	2,700	E37L421HPN272MCB7M	50×117	CB7	35	9.5	11.5	13.4
	2,900	E37L421HPN292MCD0M	50×130	CD0	33	10.3	12.3	14.4
	2,200	E37L421CPN222MD92M	63.5×92	D92	45	8.7	10.5	12.2
	2,700	E37L421CPN272MDA5M	63.5×105	DA5	37	10.1	12.1	14.2
	3,300	E37L421CPN332MDB7M	63.5×117	DB7	30	11.6	14.0	16.3
	3,900	E37L421CPN392MDD0M	63.5×130	DD0	26	13.1	15.7	18.4
	4,700	E37L421CPN472MDE3M	63.5×143	DE3	21	14.9	17.9	20.9
	3,900	E37L421CPN392ME92M	76.2×92	E92	27	12.7	15.2	17.7
	4,700	E37L421CPN472MEA5M	76.2×105	EA5	22	14.5	17.4	20.3
	5,600	E37L421CPN562MEB7M	76.2×117	EB7	18	16.4	19.7	23.0
	6,800	E37L421CPN682MEE3M	76.2×143	EE3	15	19.4	23.3	27.2
	8,200	E37L421CPN822MEJ1M	76.2×181	EJ1	13	23.3	28.0	32.7
	12,000	E37L421CPN123MEM9M	76.2×219	EM9	9	30.4	36.5	42.6
	5,600	E37L421CPN562MF92M	89×92	F92	18	16.6	20.0	23.3
	6,800	E37L421CPN682MFA5M	89×105	FA5	15	19.1	22.9	26.7
	6,800	E37L421CPN682MFB7M	89×117	FB7	15	19.8	23.8	27.8
	10,000	E37L421CPN103MFE3M	89×143	FE3	10	25.7	30.9	36.0
	10,000	E37L421CPN103MFF5M	89×155	FF5	10	26.5	31.8	37.1
12,000	E37L421CPN123MFK0M	89×190	FK0	9	31.3	37.6	43.9	
15,000	E37L421CPN153MFM9M	89×219	FM9	7	37.0	44.5	51.9	

(注1) 端子, 安装和结构的选择请参考产品型号体系说明。

(注2) 详细的外壳尺寸规格参见尺寸图。

U37L系列

标准品一览表

额定电压 (WVDC)	容量 (μF)	产品型号 (注1)	尺寸 (注2) φD×L (mm)	尺寸代码	最大ESR(mΩ) 25℃,120Hz	额定纹波电流(A rms) 85℃		
						120Hz	300Hz	>3kHz
450 浪涌电压500	2,200	E37L451HPN222MCB7M	50×117	CB7	43	8.6	10.3	12.1
	2,200	E37L451HPN222MCD0M	50×130	CD0	43	8.9	10.7	12.5
	2,200	E37L451CPN222MD92M	63.5×92	D92	45	8.7	10.5	12.2
	2,200	E37L451CPN222MDA5M	63.5×105	DA5	45	9.1	11.0	12.8
	2,700	E37L451CPN272MDB7M	63.5×117	DB7	37	10.5	12.6	14.7
	3,300	E37L451CPN332MDD0M	63.5×130	DD0	30	12.1	14.5	16.9
	3,900	E37L451CPN392MDE3M	63.5×143	DE3	26	13.6	16.3	19.0
	3,300	E37L451CPN332ME92M	76.2×92	E92	31	11.6	14.0	16.3
	3,900	E37L451CPN392MEA5M	76.2×105	EA5	27	13.2	15.8	18.5
	4,700	E37L451CPN472MEB7M	76.2×117	EB7	22	15.1	18.1	21.1
	5,600	E37L451CPN562MEE3M	76.2×143	EE3	18	17.6	21.2	24.7
	6,800	E37L451CPN682MEJ1M	76.2×181	EJ1	15	21.2	25.5	29.7
	10,000	E37L451CPN103MEM9M	76.2×219	EM9	10	27.8	33.3	38.9
	4,700	E37L451CPN472MF92M	89×92	F92	22	15.2	18.3	21.3
	5,600	E37L451CPN562MFA5M	89×105	FA5	18	17.3	20.8	24.2
	5,600	E37L451CPN562MFB7M	89×117	FB7	18	18.0	21.6	25.2
	8,200	E37L451CPN822MFE3M	89×143	FE3	13	23.3	28.0	32.6
	8,200	E37L451CPN822MFF5M	89×155	FF5	13	24.0	28.8	33.6
12,000	E37L451CPN123MFK0M	89×190	FK0	9	31.3	37.6	43.9	
12,000	E37L451CPN123MFM9M	89×219	FM9	9	33.1	39.8	46.4	
500 浪涌电压550	1,500	E37L501HPN152MCB7M	50×117	CB7	64	7.1	8.5	10.0
	1,500	E37L501HPN152MCD0M	50×130	CD0	64	7.4	8.9	10.3
	1,800	E37L501CPN182MD92M	63.5×92	D92	55	7.9	9.5	11.1
	2,200	E37L501CPN222MDA5M	63.5×105	DA5	45	9.1	11.0	12.8
	2,200	E37L501CPN222MDB7M	63.5×117	DB7	45	9.5	11.4	13.3
	2,700	E37L501CPN272MDD0M	63.5×130	DD0	37	10.9	13.1	15.3
	2,700	E37L501CPN272MDE3M	63.5×143	DE3	37	11.3	13.6	15.8
	2,700	E37L501CPN272ME92M	76.2×92	E92	38	10.5	12.6	14.7
	3,300	E37L501CPN332MEA5M	76.2×105	EA5	31	12.1	14.6	17.0
	3,300	E37L501CPN332MEB7M	76.2×117	EB7	31	12.6	15.2	17.7
	4,700	E37L501CPN472MEE3M	76.2×143	EE3	22	16.2	19.4	22.6
	5,600	E37L501CPN562MEJ1M	76.2×181	EJ1	18	19.3	23.1	27.0
	8,200	E37L501CPN822MEM9M	76.2×219	EM9	13	25.2	30.2	35.2
	3,900	E37L501CPN392MF92M	89×92	F92	27	13.9	16.6	19.4
	3,900	E37L501CPN392MFA5M	89×105	FA5	27	14.5	17.3	20.2
	4,700	E37L501CPN472MFB7M	89×117	FB7	22	16.5	19.8	23.1
	6,800	E37L501CPN682MFE3M	89×143	FE3	15	21.2	25.5	29.7
	6,800	E37L501CPN682MFF5M	89×155	FF5	15	21.9	26.2	30.6
8,200	E37L501CPN822MFK0M	89×190	FK0	12	26.7	32.0	37.4	
10,000	E37L501CPN103MFM9M	89×219	FM9	9	33.1	39.8	46.4	

(注1) 端子, 安装和结构的选择请参考产品型号体系说明。

(注2) 详细的外壳尺寸规格参见尺寸图。