

iC-LGC

21-BIT OPTICAL POSITION ENCODER WITH SERIAL/PARALLEL AND SIN/COS OUTPUT



iC-LGC is an optoelectronic encoder iC for absolute position sensors. Photosensors, amplifiers and comparators, the entire signal conditioning and data processing unit and fast I/O interfaces are monolithically integrated on the chip.

Applications

- Absolute position encoders for safety-related controls
- Analog and digital motor feedback systems
- Robotics, tooling machines, servo drives

Features

- System-on-chip design with integrated photosensors
- Excellent matching and reliability
- Differential scanning for EMI immunity and operation up to 125 °C
- Enlarged assembly tolerance due to pre-positioned and post-positioned code scanning
- 13 digital tracks pitched at just 500 µm
- 2 sine/cosine tracks with analog signal conditioning
- Singleturn resolution of 16 to 21 bits by 3-bit flash or 8-bit S&H ADC
- Multiturn data processing via 2-pin A/B or SSI interface, embedded low power counter for battery supply
- LED power control with a 50 mA highside driver
- Adjustable temperature sensor with min/max alarm
- Operational monitoring and alarm/warning messaging: missing code step, disc data error, configuration error, LED end-of-life, out-of-range temperature
- Safety features: CRC-protected setup with verification, CRC-protected data output with life counter
- Operating modes: hardware encoder (up to 16 bits), serial encoder (SSI, BiSS C), parallel encoder (8-bit parallel µC)
- 4 to 5.5 V single supply operation, low power consumption
- Small-outline optoBGA or BLCC package for SMT
- Available accessories: LED lamps and code discs
- Options: extended temperature range of -40 to +125 °C, customized COB modules, customized code designs

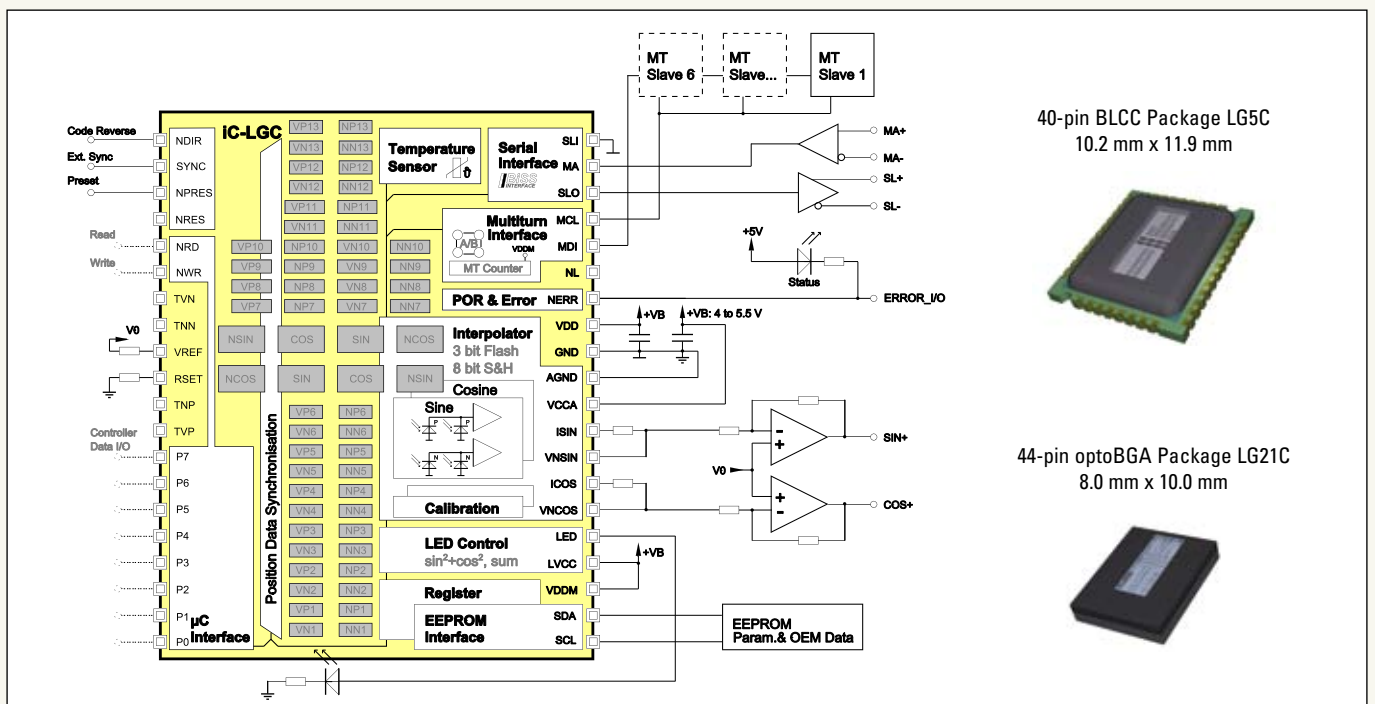

40-pin BLCC Package LG5C
10.2 mm x 11.9 mm

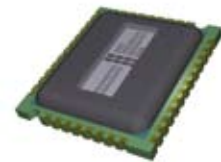

44-pin optoBGA Package LG21C
8.0 mm x 10.0 mm



iC-LGC 21-BIT OPTICAL POSITION ENCODER

The scanning unit uses pre-positioned and post-positioned photosensors for each track to ease encoder assembly by moderating tolerances. Differential evaluation of all sensors enables operation at high ambient temperatures. An integrated LED power control with a highside driver guarantees illumination regardless of temperature or ageing effects.

The chip features offset and amplitude calibration for the analog output signals also fed to the integrated 3-bit flash and the 8-bit SAR interpolators.

External multiturn sensors can be operated via an SSI or A/B counter interface; the count is maintained when a backup battery is connected. iC-LGC synchronizes and combines all data to generate a single-step-proof position data word. The chip's operation is monitored with configurable alarms; CRC verification of configuration data is also available.

The serial I/O interface in BiSS C protocol (SSI is optional) has permanent bidirectional register communication. The user can access released data areas (e.g. OEM data in the EEPROM) without interfering with control cycles. Alternatively, the 8-bit parallel microcontroller interface can be used for configuration and data exchange.

Pin Functions

Name	Pin Function
VDD, VCCA	+4 V to +5.5 V Digital and Analog Supply Voltage
GND, AGND	Digital and Analog Ground
VDDM	+3.0 to +5.5 V MT Counter Supply Voltage
LVCC	+4 V to +5.5 V LED Driver Supply Voltage
LED	LED Current Source Output
RSET	LED Power Control Adjustment
VNSIN, VNCOS	Inverted Sin/Cos Voltage Outp. [Alignm. D1, D0]
ISIN, ICOS	Sin/Cos Current Outputs
VREF	+2.5 V Reference Voltage Output
NPRES	Preset Input / Alignment Mode Enable
NRES	Reset Input / Reset Indication Output
NDIR	Code Direction Reversal
NERR	Error Message Output / System Error Input
SCL	EEPROM Interface, Clock Output
SDA	EEPROM Interface, Data Line
MDI D(15)	MT Interface, Data Input or Counter Input B / Parallel Data Output
MCL D(14)	MT Interface, Clock Output or Counter Input A / Parallel Data Output
SLO D(13)	I/O Interface, Data Output / Parallel Data Output [Alignm. V1 xor V13, TP]
MA D(12)	I/O Interface, Clock Input / Parallel Data Output
SLI D(11)	I/O Interface, Data Input / Parallel Data Output
SYNC D(10)	Synchronization Input / Parallel Data Output
NRD D(9)	μ C Read Signal / Parallel Data Output
NWR D(8)	μ C Write Signal / Parallel Data Output
P(7...0) D(7...0)	μ C Data Bus / Parallel Data Output
NL	μ C Data Request Input / Par. Data Output Latch
TVN, TNN, TNP, TVP	Test Mode Current Inputs

This tentative information shall not be considered as a guarantee of characteristics. Rights to technical changes reserved.

Key Specifications

General	
Supply Voltage	4 V to 5.5 V, typ. 10 mA
MT Counter Supply	3.3 V to 5.5 V, typ. 4 μ A during power-down
On-Chip Oscillator	5 MHz
LED Power Control	50 mA max. (highside current source output)
ESD Susceptibility	2 kV (HBM 100 pF, 1.5 k Ω)
Operational Temperature Range	-20 °C to +90 °C (-40 °C to +125 °C optional)
Chip Size	3.5 mm x 7 mm
Packages (RoHS compliant)	40-pin BLCC LG5C (10.2 x 11.9 x 1.6 mm) 44-pin optoBGA LG21C (8.0 x 10.0 x 1.6 mm)
Options	on-chip reticle, reference code discs

Position Acquisition	
Singleturn Resolution	to 21 bits / 360° (@ sin/cos 8,192 PPR)
Multiturn Resolution	to 24 bits
Angle Resolution	Disc LG2S 42-2048: 11+8 bits (524,288 CPT) Disc LG3S 42-4096: 12+8 bits (1,048,576 CPT)
Absolute Angle Accuracy	+/- 1 LSB @ 19 bits (mounted within 0.7 degree tilt angle)
Operating Speed	12,000 RPM max.

Temperature Monitoring	
Range, Resolution	-64 °C to +191 °C, resolution 1 °C (LSB)
Alarm Output	adjustable high/low alarm thresholds

Data Interfaces	
Serial I/O Interface	BiSS C, uni-/bidirectional, to 10 MHz SSI, binary or Gray coded, to 4 MHz
μ C Interface	8-bit data bus, 1 MHz access cycle per byte
MT Interface	2-pin A/B quadrature counter, to 300 Hz 2-pin serial SSI (200 kHz, 12+1 to 24+1 bit, 1 binary word or 3 to 6 Gray-coded words)
Analog Outputs	calibrated sine/cosine, 250 mVp, to 500 kHz
EEPROM Interface	I ² C compatible, to 16 kbit, CRC error detection

Data And Control Registers (RAM)	
Position Data	3 bytes for singleturn (with interpolation), 3 bytes for multiturn, 2 bytes for CRC
Temperature Data	1 byte
Calibration Data	5 bytes (signal conditioning, temperature sensor)
Configuration and Operation	33 bytes CRC-protected configuration, error byte, life counter byte, command/status byte; BiSS C direct access registers (bank switch, EDS, profile, S/N, ID and measurement data)

Operational Functions	
Parameterization	interface mode, resolution, disc model, multiturn functions, output formats, code direction, alarm messaging
Position Preset	via interfaces, or pin-triggered execution
Monitoring & Alarm	missing code step, corrupted single/multiturn data (disc error), EEPROM link error, illumination error (LED end-of-life), out-of-range temperature
Test and Alignment	analog sensor stimulation, alignment aids for radial position and tilt angle
Setup	EEPROM, μ C Interface or serial I/O (BiSS C)