

LSHC9S 33-512N, LSHC9R

iC-LSHC Encoder Disc and Reticle



Rev A2, Page 1/3

CODE DISC ORDERING INFORMATION

| Type | Order Designation | Description/Options |
|--------------|-------------------|--|
| Encoder Disc | LSHC9S 33-512N | Nonius Code Disc 512 PPR, dia 33 mm |

PHYSICAL DIMENSIONS

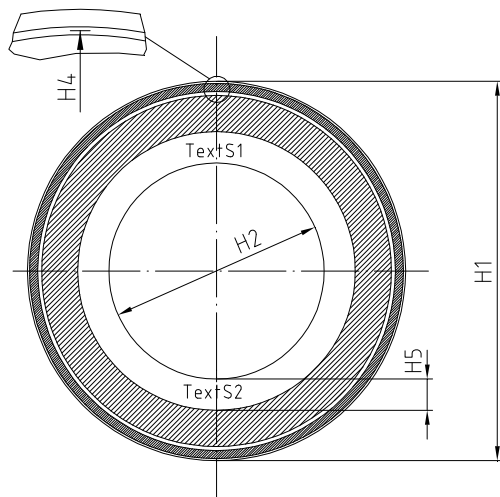

Design Example

| Item | Parameter | Comments | [mm] | Tolerance |
|------|--------------------------------|----------------------------------|-----------|-----------------------|
| H1 | Outer Diameter | | 33.0 | $\pm 100 \mu\text{m}$ |
| H2 | Inner Diameter | | 18.0 | $+ 200 \mu\text{m}$ |
| H3 | Thickness | | 1 | $\pm 100 \mu\text{m}$ |
| H4 | Radius of Chip Center | referred to origin | 14.5 | |
| H5 | Distance Pattern to Drill Hole | | 2.3 | |
| H6 | Code Track Eccentricity | referred to center of inner hole | ± 0.2 | |
| H7 | TextS1 | readable on side of pattern | LSHC9S | |
| H8 | TextS2 | readable on side of pattern | 33-512 | |

TRACK LAYOUT

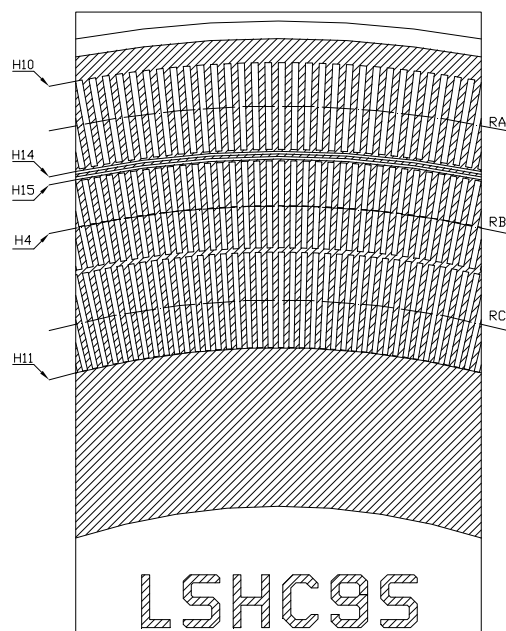

| Item | Parameter | Comments | [mm] |
|------|-------------------------------|----------------------------------|---------|
| H4 | Radius of Chip Center | referred to origin | 14.500 |
| H10 | Code Pattern Radius | end | 16.125 |
| H11 | Code Pattern Radius | begin | 12.895 |
| H12 | Recommended LED Spot Diameter | LED Spot | > 3.2 |
| H13 | Recommended LED Spot Center | radius as center of illumination | 14.500 |
| H14 | Alignment Circle | end of circle | 15.120 |
| H15 | Alignment Circle | begin of circle | 15.030 |
| RA | Track Radius | RA | 15.805 |
| RB | Track Radius | RB | 15.355 |
| RC | Track Radius | RC | 14.725 |
| RD | Track Radius | RD | 14.275 |
| RE | Track Radius | RE | 13.645 |
| RF | Track Radius | RF | 13.195 |

LSHC9S 33-512N, LSHC9R

iC-LSHC Encoder Disc and Reticle



Rev A2, Page 2/3

PHYSICAL DIMENSIONS: Reticle

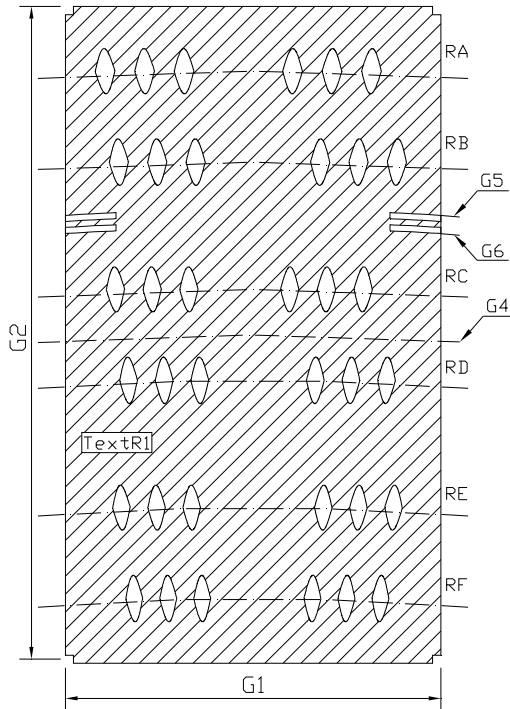

| Item | Parameter | Comments | [mm] | Tolerance |
|------|-----------------------|-----------------------------|--------|-----------|
| G1 | Width | | 1.90 | |
| G2 | Height | | 3.30 | |
| G3 | Thickness | | 0.50 | ± 10% |
| G4 | Radius of Chip Center | referred to origin | 14.500 | |
| G5 | Alignment Circle | end of circle | 15.120 | |
| G6 | Alignment Circle | begin of circle | 15.030 | |
| G7 | TextR1 | readable on side of pattern | LSHC9R | |
| RA | Track Radius Nonius | RA | 15.805 | |
| RB | Radius Track Nonius | RB | 15.355 | |
| RC | Track Radius Master | RC | 14.725 | |
| RD | Track Radius Master | RD | 14.275 | |
| RE | Track Radius Segment | RE | 13.645 | |
| RF | Track Radius Segment | RF | 13.195 | |

TRACK ASSIGNMENT: Reticle

| Output | Signal | Signal | Output |
|--------|---------------|---------------|--------|
| A1 | 511 PPR PSINN | 511 PPR PCOSN | A2 |
| B1 | 511 PPR NCOSN | 511 PPR NSINN | B2 |
| C1 | 512 PPR PSINM | 512 PPR PCOSM | C2 |
| D1 | 512 PPR NCOSM | 512 PPR NSINM | D2 |
| E1 | 496 PPR PSINS | 496 PPR PCOSS | E2 |
| F1 | 496 PPR NCOSS | 496 PPR NSINS | F2 |

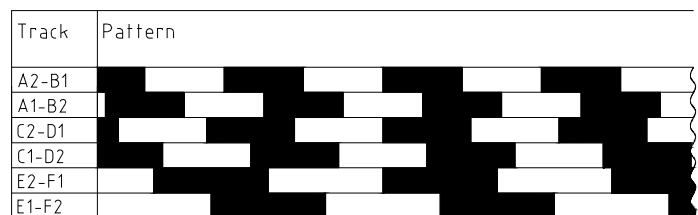

LSHC9S 33-512N, LSHC9R

iC-LSHC Encoder Disc and Reticle



Rev A2, Page 3/3

PHYSICAL DIMENSIONS: Photosensor Array

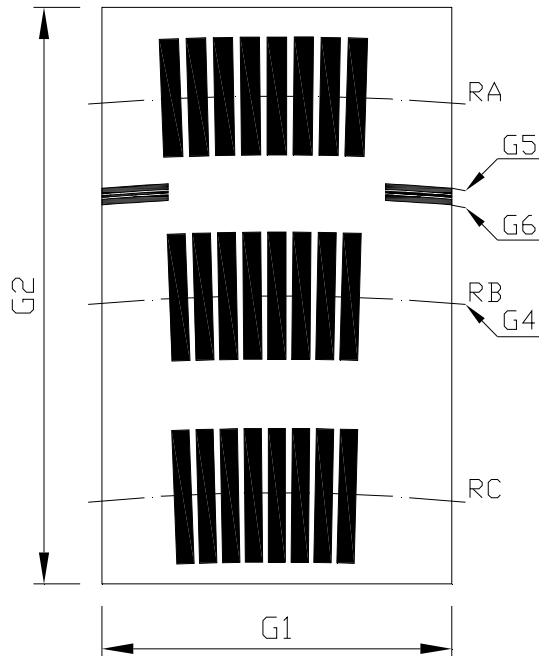

| Item | Parameter | Comments | [mm] |
|------|--------------------------|--------------------|--------|
| G0 | Name and Design Release | iC-PN3312 | |
| G1 | Window Width | | 1.90 |
| G2 | Window Height | | 3.24 |
| G4 | Radius of Chip Center | referred to origin | 14.500 |
| G5 | Reflective Alignment Aid | end of circle | 15.120 |
| G6 | Reflective Alignment Aid | begin of circle | 15.030 |
| RA | Track Radius Nonius | | 15.580 |
| RB | Track Radius Master | | 14.500 |
| RC | Track Radius Segment | | 13.420 |

TRACK ASSIGNMENT: Photosensor Array

| Radius | Signal | | | |
|--------|------------------|------------------|------------------|------------------|
| | RA | 511 PPR PSINN | 511 PPR PCOSN | 511 PPR NSINN |
| RB | 512 PPR PSINM | 512 PPR PCOSM | 512 PPR NSINM | 512 PPR NCOSM |
| RC | 496 PPR PSINS | 496 PPR PCOSS | 496 PPR NSINS | 496 PPR NCOSS |

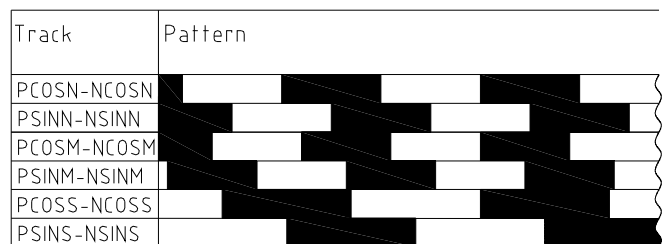

iC-Haus expressly reserves the right to change its products and/or specifications. An info letter gives details as to any amendments and additions made to the relevant current specifications on our internet website www.ichaus.com/infoletter; this letter is generated automatically and shall be sent to registered users by email. Copying – even as an excerpt – is only permitted with iC-Haus approval in writing and precise reference to source. iC-Haus does not warrant the accuracy, completeness or timeliness of the specification on this site and does not assume liability for any errors or omissions in the materials. The data specified is intended solely for the purpose of product description. No representations or warranties, either express or implied, of merchantability, fitness for a particular purpose or of any other nature are made hereunder with respect to information/specification or the products to which information refers and no guarantee with respect to compliance to the intended use is given. In particular, this also applies to the stated possible applications or areas of applications of the product. iC-Haus conveys no patent, copyright, mask work right or other trade mark right to this product. iC-Haus assumes no liability for any patent and/or other trade mark rights of a third party resulting from processing or handling of the product and/or any other use of the product. As a general rule our developments, IPs, principle circuitry and range of Integrated Circuits are suitable and specifically designed for appropriate use in technical applications, such as in devices, systems and any kind of technical equipment, in so far as they do not infringe existing patent rights. In principle the range of use is limitless in a technical sense and refers to the products listed in the inventory of goods compiled for the 2008 and following export trade statistics issued annually by the Bureau of Statistics in Wiesbaden, for example, or to any product in the product catalogue published for the 2007 and following exhibitions in Hanover (Hannover-Messe). We understand suitable application of our published designs to be state-of-the-art technology which can no longer be classed as inventive under the stipulations of patent law. Our explicit application notes are to be treated only as mere examples of the many possible and extremely advantageous uses our products can be put to.