

iC-HB

TRIPLE 155 MHz LASER SWITCH



Rev A4, Page 1/8

FEATURES

- Laser switch for frequencies from CW up to 155 MHz
- Spike-free switching of the laser currents
- Three channels with independent current control at pins CIx
- Operates as a voltage-controlled current sink
- LVDS/TTL switching inputs with TTL monitor outputs
- Pulsed operation with up to 300 mA per channel
- CW operation with up to 65 mA per channel
- Laser current monitor output
- Thermal shutdown with open drain error output
- Protective ESD circuitry

APPLICATIONS

- Laser printers
- Data transmission
- Laser scanning devices

PACKAGES

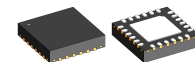

QFN24
4 mm x 4 mm

BLOCK DIAGRAM

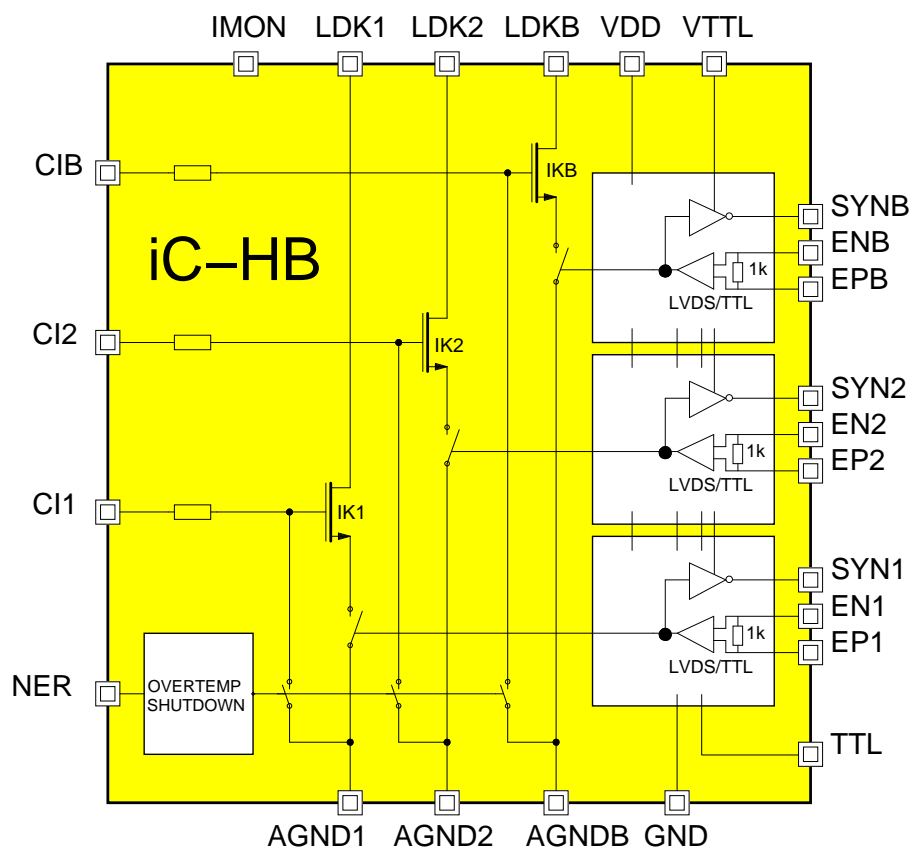

DESCRIPTION

Triple Laser Switch iC-HB enables the spike-free switching of laser diodes with well-defined current pulses at frequencies ranging from DC to 155 MHz.

The diode current is determined by the voltages at pins Clx.

The three fast switches are controlled independently via LVDS/TTL inputs. Input TTL = hi selects TTL type inputs. The laser diode can thus be turned on and off or switched between different current levels (LDKx connected) defined by the voltages at CI1, CI2 and CIB. Channel B is preferably used for biasing.

For current monitoring purpose IMON sinks a fraction of the sum of currents into LDKx:

$$I(IMON) = \frac{I(LDK_1) + I(LDK_2)}{92} + \frac{I(LDK_B)}{75}$$

Each channel can be operated at 65 mA DC (channel B: 60 mA) and up to 300 mA (channel B: 275 mA) pulsed current depending on the frequency, duty cycle and heat dissipation.

The integrated thermal shutdown feature protects the IC from damage by excessive temperature.

PACKAGING INFORMATION QFN24 to JEDEC

PIN CONFIGURATION QFN24 4 mm x 4 mm

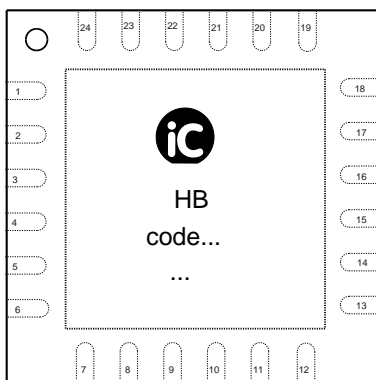

PIN FUNCTIONS

No.	Name	Function
1	AGND2	Analogue ground channel 2
2	LDK2	Laser diode cathode channel 2
3	LDKB	Laser diode cathode channel B
4	AGNDB	Analogue ground channel B
5	LDK1	Laser diode cathode channel 1
6	AGND1	Analogue ground channel 1

PIN FUNCTIONS

No.	Name	Function
7	EP1	Positive LVDS/TTL switching input channel 1
8	EN1	Negative LVDS switching input channel 1
9	SYN1	Sync output channel 1
10	VTTL	Sync TTL output supply voltage
11	SYNB	Sync output channel B
12	CI1	Current control voltage channel 1
13	ENB	Negative LVDS switching input channel B
14	EPB	Positive LVDS/TTL switching input channel B
15	VDD	+5 V supply voltage
16	GND	Ground
17	CIB	Current control voltage channel B
18	IMON	Laser diode current monitor output
19	CI2	Current control voltage channel 2
20	NER	Temperature shutdown monitor output
21	TTL	TTL inputs selector (EPx)
22	SYN2	Sync output channel 2
23	EN2	Negative LVDS switching input channel 2
24	EP2	Positive LVDS/TTL switching input channel 2

For improved heat dissipation the *thermal pad* is to be connected to a ground plane on the PCB.

Only pin 1 marking on top or bottom defines the package orientation (Ⓢ HB label and coding is subject to change).

ABSOLUTE MAXIMUM RATINGS

Beyond these values damage may occur; device operation is not guaranteed.

Item No.	Symbol	Parameter	Conditions			Unit
				Min.	Max.	
G001	VDD	Voltage at VDD		-0.7	6	V
G002	I(VDD)	Current in VDD		-10	150	mA
G003	V(CIx)	Voltage at CI1, CI2, CIB		-0.7	6	V
G004	I(LDKc)	Current in LDK1, LDK2, LDKB	DC current	-10	300	mA
G005	I(AGND1)	Current in AGND1, AGND2, AGNDB	DC current	-150	10	mA
G006	V()	Voltage at EN1, EN2, AGND1, AGND2, AGNDB		-0.7	6	V
G007	V(LDKx)	Voltage at LDK1, LDK2, LDKB		-0.7	6	V
G008	Vd()	Susceptibility to ESD at all pins	HBM, 100 pF discharged through 1.5 kΩ		4	kV
G009	Tj	Operating Junction Temperature		-40	150	°C
G010	Ts	Storage Temperature Range		-40	150	°C

THERMAL DATA

Operating Conditions: VDD = 3.5...5.5 V, VTTL = 3.15...5.5 V

Item No.	Symbol	Parameter	Conditions				Unit
				Min.	Typ.	Max.	
T01	Ta	Operating Ambient Temperature Range (extended range on request)		-25		85	°C
T02	Rthja	Thermal Resistance Chip/Ambient	soldered to PCB, therm. pad soldered to approx. 2 cm ² cooling area		30	60	K/W

All voltages are referenced to ground unless otherwise stated.

All currents flowing into the device pins are positive; all currents flowing out of the device pins are negative.

ELECTRICAL CHARACTERISTICS

Operating Conditions: VDD = 3.5...5.5 V, VTTL = 3.15...5.5 V, Tj = -25...125 °C unless otherwise stated

Item No.	Symbol	Parameter	Conditions				Unit
				Min.	Typ.	Max.	
Total Device							
001	VDD	Permissible Supply Voltage		3.5		5.5	V
002	VTTL	Permissible Supply Voltage at VTTL		3.15		5.5	
003	I(VDD)	Supply Current in VDD	CW operation	2		8	mA
004	I(VDD)	Supply Current in VDD	pulsed operation, f(ENx, EPx) = 150 MHz			80	mA
005	I(VTTL)	Supply Current in VTTL				1	mA
006	V(LDKx)	Permissible Voltage at LDK1, LDK2, LDKB		0		5.5	V
007	Vc(Clx)hi	Clamp Voltage hi at Cl1, Cl2, ClB	Vc(Clx) = V(Clx) – VDD, I(Clx) = 10 mA, other pins open	0.4		1.25	V
008	Vc(TTL)hi	Clamp Voltage hi at TTL	Vc(TTL)hi = V(TTL) – VDD, I(TTL) = 0.1 mA, other pins open	0.4		1.25	V
009	Vc(SYNx)hi	Clamp Voltage hi at SYN1, SYN2, SYNB	Vc(SYNx)hi = V(SYNx) – VTTL, I(EN) = 1 mA, other pins open	0.4		1.25	V
010	Vc(lo)	Clamp Voltage lo at VDD, LDK, Cl1, Cl2, ClB, EN1, EN2, ENB, EP1, EP2, EPB, TTL, AGND1, AGND2, AGNDB, NER, VTTL, SYN1, SYN2, SYNB, IMON	I() = -10 mA, other pins open	-1.25		-0.4	V
011	Ipd()	Pull-Down Current at Cl1, Cl2, ClB, TTL	V() = 0.7...5.5 V	0.5		5	μA
012	Ipd(EPx)	Pull-Down Current at EP1, EP2, EPB	TLL = hi, V() = 0.7...5.5 V	0.5		5	μA
013	Toff	Overtemperature Shutdown		120		165	°C
Laser Control							
101	Icw(LDKx)	Permissible CW Current in LDK1, LDK2				65	mA
102	Icw(LDKB)	Permissible CW Current in LDKB				60	mA
103	Ipk(LDKx)	Permissible Pulsed Current in LDK1, LDK2	f > 100 kHz, t _{hi} / T < 1:10			300	mA
104	Ipk(LDKB)	Permissible Pulsed Current in LDKB	f > 100 kHz, t _{hi} / T < 1:10			275	mA
105	Vsat(LDKx)	Saturation Voltage at LDK1, LDK2, LDKB	I(LDKx) = 30 mA I(LDKx) = 60 mA			0.8 1.2	V V
106	Imon()	Switching Channels 1, 2	V(IMON) > 1.5 V, V(LDKx) > 1.5 V	1/105		1/85	I(LDKx)
107	Imon()	Bias Channel	V(IMON) > 1.5 V, V(LDKx) > 1.5 V	1/80		1/70	I(LDKB)
108	I0(LDKx)	Leakage Current in LDK1, LDK2, LDKB	V(EPx) < V(ENx), V(LDKx) = VDD	0		10	μA
109	tr()	Current Rise Time at LDK1, LDK2, LDKB	Iop(LDKx) = 55 mA, I(LDKx): 10% → 90%Iop, cf. Fig. 1			1.5	ns
110	tf()	Current Fall Time at LDK1, LDK2, LDKB	Iop(LDKx) = 55 mA, I(LDKx): 90% → 10%Iop, cf. Fig. 1			1.5	ns
111	tp()	Propagation Delay V(EPx, ENx) → I(LDKx)			10		ns
112	Vcm()	Common Mode Input Voltage Range at ENx, EPx	TLL = lo; VDD = 3.5...5.5 V VDD = 4.5...5.5 V	0.8 0.6		2.3 2.3	V V
113	Vd()	Input Differential Voltage at ENx, EPx	TLL = lo	-100		100	mV
114	R()	Differential Input Impedance at ENx, EPx	TLL = lo, V(ENx) < VDD – 2 V, V(EPx) < VDD – 2 V	0.6		3	kΩ
115	Vt(TTL)hi	Input Threshold Voltage hi				2	V
116	Vt(TTL)lo	Input Threshold Voltage low	VDD = 5 V	0.8			V
117	Vhys(TTL)	Hysteresis			100		mV

ELECTRICAL CHARACTERISTICS

Operating Conditions: VDD = 3.5...5.5 V, VTTL = 3.15...5.5 V, Tj = -25...125 °C unless otherwise stated

Item No.	Symbol	Parameter	Conditions	Min.	Typ.	Max.	Unit
118	Vt(EPx)hi	Input Threshold Voltage hi at EP1, EP2, EPB	TTL = hi, ENx = open			2	V
119	Vt(EPx)lo	Input Threshold Voltage low at EP1, EP2, EPB	TTL = hi, ENx = open	0.8			
120	Vhys(EPx)	Hysteresis			20		mV
121	Vt(CIx)	Threshold Voltage at CI1, CI2, CIB	I(LDKx) < 5 mA	0.9		1.4	V
122	CR()	Current Matching Channel1 / Channel2	V(CI1) = V(CI2) = 0...VDD, I(LDKx) = 30...300 mA	0.9		1.1	
123	I(NER)	Current in NER	Tj > Toff, V(NER) > 0.6 V	1		20	mA
124	Vsat(NER)	Saturation Voltage at NER	Tj > Toff, I(NER) = 1 mA			600	mV
125	Vs(SYNx)hi	Saturation Voltage hi at SYN1, SYN2, SYNB	Vs(SYNx)hi = VDD - V(SYNx), I() = -1 mA, V(EPx) < V(ENx)			0.4	V
126	Vs(SYNx)lo	Saturation Voltage lo at SYN1, SYN2, SYNB	I() = 1 mA, V(EPx) > V(ENx)			0.4	V
127	Isc(SYNx)hi	Short-Circuit Current hi at SYN1, SYN2, SYNB	V(EPx) < V(ENx), V(SYNx) = 0 V, VTTL = 3.3 V	-20		-3	mA
128	Isc(SYNx)lo	Short-Circuit Current lo at SYN1, SYN2, SYNB	V(EPx) > V(ENx), V(SYNx) = VTTL, VTTL = 3.3 V	3		20	mA

ELECTRICAL CHARACTERISTICS DIAGRAMS

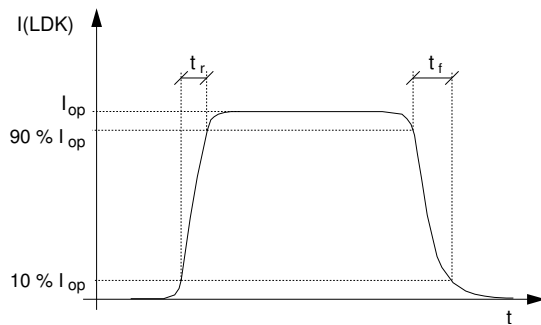

Figure 1: Laser current pulse in LDK

CURRENT CONTROL

The voltage at pins C11/2/B sets the current in pins LDK1/2/B. Figures 2 and 3 show the temperature dependency of the current in a single LDKx output versus

the voltage at C1x for a *typical* device. Figures 4 and 5 show the min., typ. and max. variations between devices at 27 °C temperature.

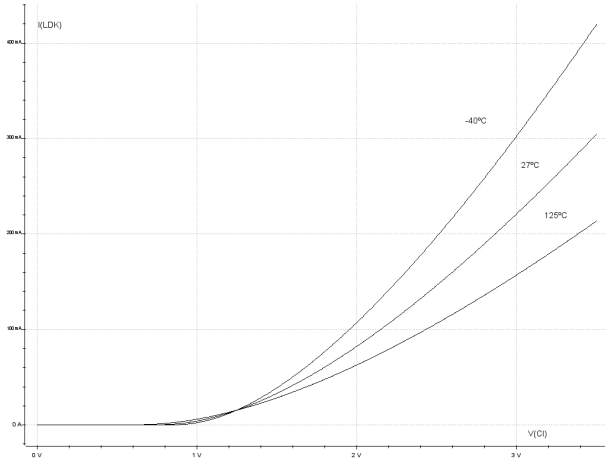

Figure 2: I(LDK1/2) vs. V(C11/2) at VDD = 5 V

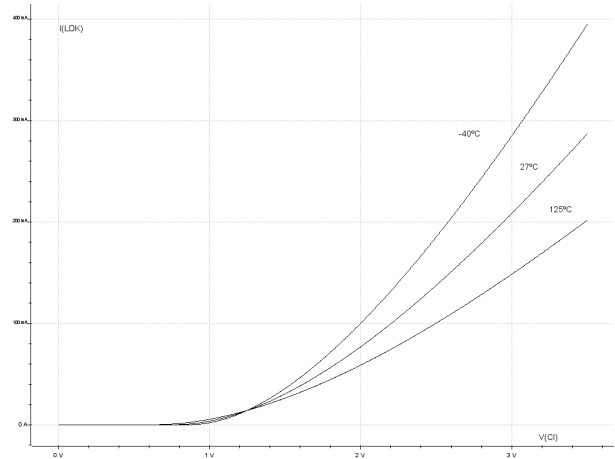

Figure 3: I(LDK1/2) vs. V(C11/2) at VDD = 3.3 V

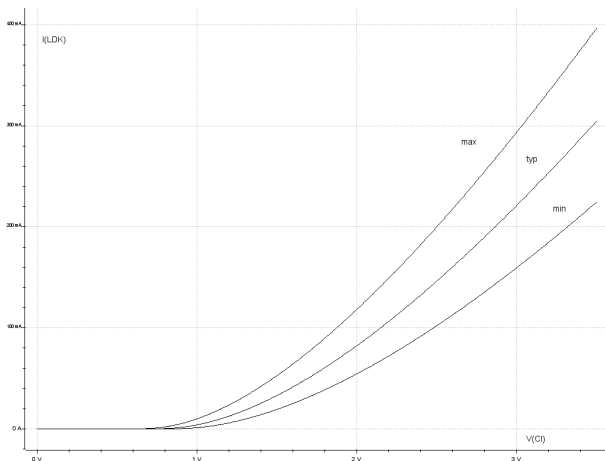

Figure 4: I(LDKx) vs. V(C1x) at VDD = 5 V

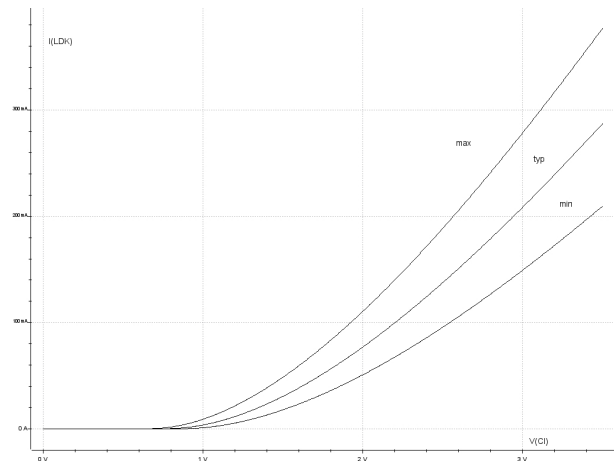

Figure 5: I(LDKx) vs. V(C1x) at VDD = 3.3 V

DEMO BOARD

iC-HB comes with a demo board for test purpose. Figures 6 and 7 show both the schematic and the component side of the demo board.

iC-HB

TRIPLE 155 MHz LASER SWITCH



Rev A4, Page 7/8

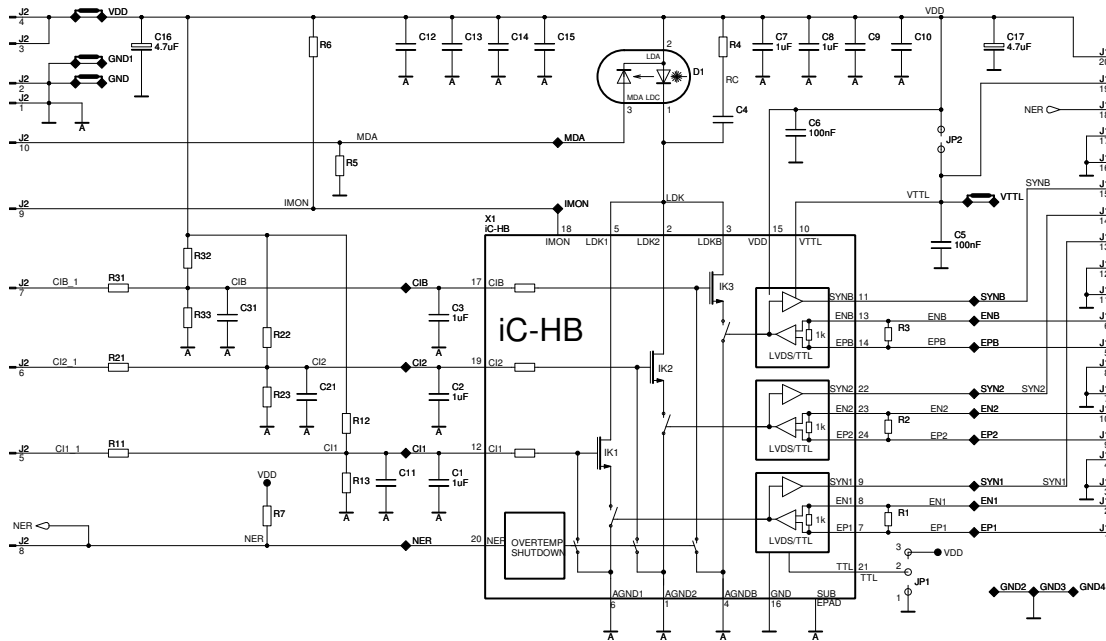

Figure 6: Schematic of the demo board

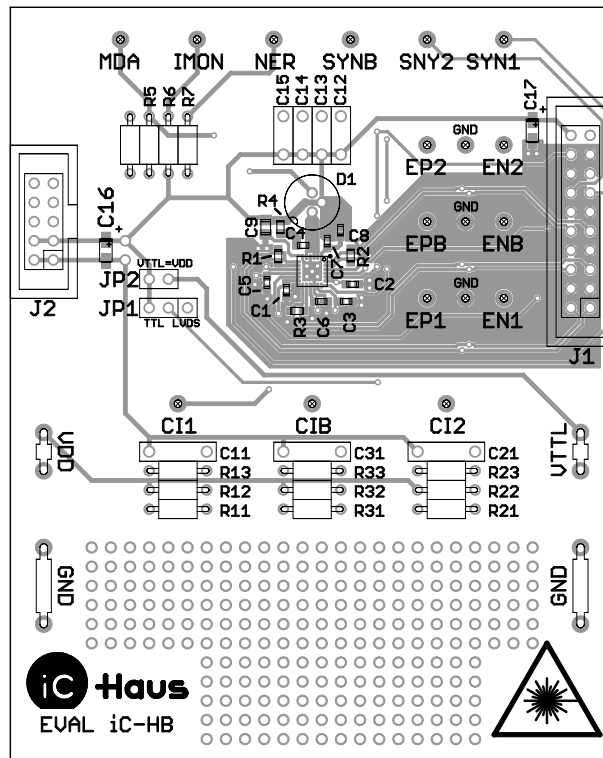

Figure 7: Demo board (component side)

iC-Haus expressly reserves the right to change its products and/or specifications. An info letter gives details as to any amendments and additions made to the relevant current specifications on our internet website www.ichaus.de/infoletter; this letter is generated automatically and shall be sent to registered users by email.

Copying – even as an excerpt – is only permitted with iC-Haus' approval in writing and precise reference to source.

iC-Haus does not warrant the accuracy, completeness or timeliness of the specification and does not assume liability for any errors or omissions in these materials.

The data specified is intended solely for the purpose of product description. No representations or warranties, either express or implied, of merchantability, fitness for a particular purpose or of any other nature are made hereunder with respect to information/specification or the products to which information refers and no guarantee with respect to compliance to the intended use is given. In particular, this also applies to the stated possible applications or areas of applications of the product.

iC-Haus conveys no patent, copyright, mask work right or other trade mark right to this product. iC-Haus assumes no liability for any patent and/or other trade mark rights of a third party resulting from processing or handling of the product and/or any other use of the product.

iC-HB

TRIPLE 155 MHz LASER SWITCH



Rev A4, Page 8/8

ORDERING INFORMATION

Type	Package	Order Designation
iC-HB	QFN24 4 mm x 4 mm	iC-HB QFN24

For technical support, information about prices and terms of delivery please contact:

iC-Haus GmbH
Am Kuemmerling 18
D-55294 Bodenheim
GERMANY

Tel.: +49 (0) 61 35-9292-0
Fax: +49 (0) 61 35-9292-192
Web: <http://www.ichaus.com>
E-Mail: sales@ichaus.com

Appointed local distributors: http://www.ichaus.com/sales_partners