

### FEATURES

- Current control for inductive actuators at 24 V (10 to 36 V)
- High efficient current control up to 1 A
- Power saving and power dissipation reduced switching
- Individual setting of energising and hold current
- Monitoring of coil current, supply voltage and temperature
- Status indication via LED or logic output
- Contact preserving switching of relays synchronous to the mains
- Shutdown with overtemperature and undervoltage
- Fast demagnetising due to 15 V countervoltage
- High PWM frequency with spreading for low EMI
- Energising time of 65 ms prolongable with external capacitor

### APPLICATIONS

- PWM driver for inductive loads (e.g. 6/12 V relays, electrovalves) from 24 V
- Relay low-/high-side switch

### PACKAGES

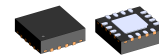

QFN16-4x4

### BLOCK DIAGRAM

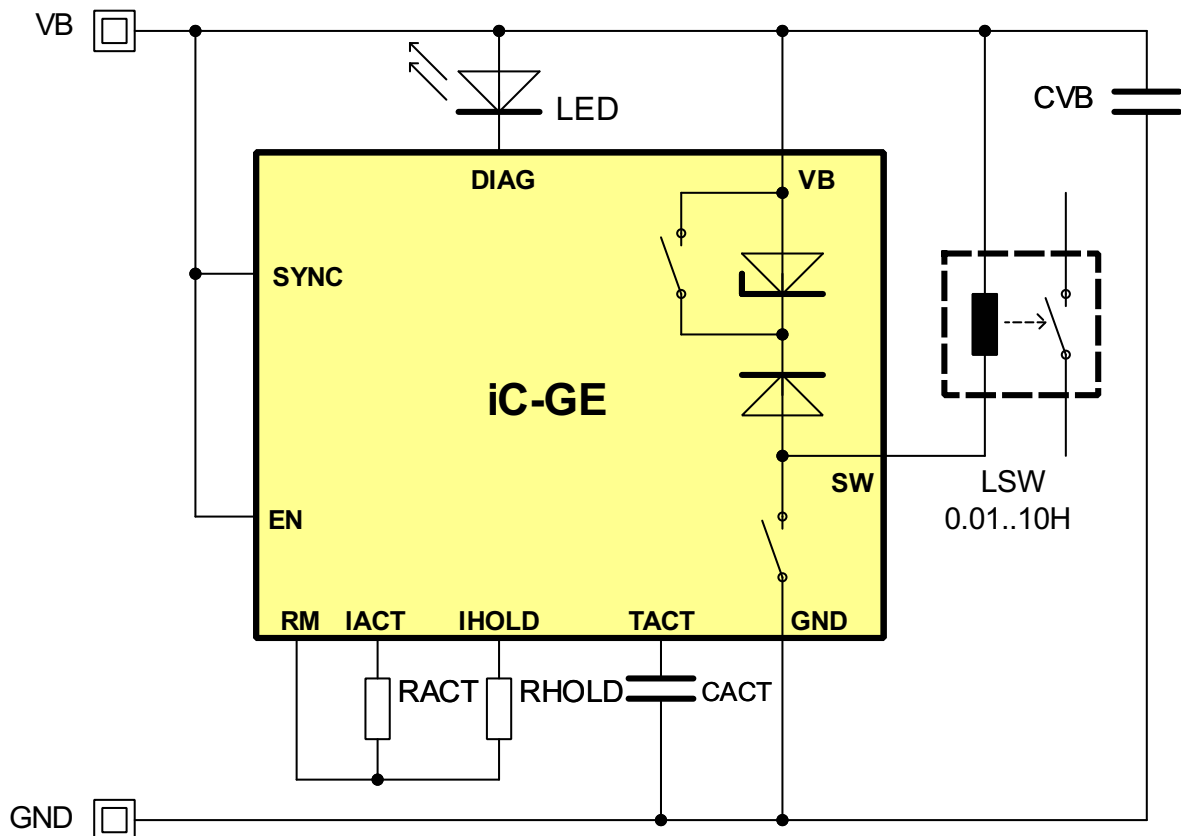

**DESCRIPTION**

iC-GE is a PWM driver for inductive loads, such as relay coils, solenoid valves and other inductive loads.

The setpoints for the coil's energising and hold current are preset by means of external resistors RACT and RHOLD. These currents can be set in a range from 100 mA to 1 A. The iC-GE intrinsically switches from energising to hold mode after 65 ms provided that the set energising current has been reached. A capacitor at TACT prolongs the time before the switch to hold mode occurs.

The changeover between energising and hold modes is suitable for typical relay drives which require a powerful initial energising current which can then be reduced after closing the air gap in a magnetic circuit. The quadratic dependence on the current intensity means that cutting the current by half reduces the power dissipation by ca. 75%.

Using PWM the output current is controlled to the values set at RACT and RHOLD. The internal fly-back diode maintains the current during the switching pauses. The switching frequency of ca. 80 kHz

is provided by the internal oscillator. Varying this frequency between 70 kHz and 90 kHz reduces the EMI.

The device is shutdown by a Low signal at input EN or the removal of the power supply; the current reduction in the coil is supported by the changeover of the free-wheeling circuit. The Zener diode now active permits higher free-wheeling voltages and thus a quicker demagnetising of the coil.

The status indicator LED is constantly ON when hold mode is functioning correctly and flashes with low voltage, excessive temperature or when the coil current in energise mode has not reached the setpoint. The driver output is shutdown with low voltage or excessive temperature. Alternatively to using an LED output DIAG signals the correct operating by outputting a high signal.

The input signal at EN can be synchronised with the zero crossing at input SYNC. Thus by using an external R/C network, the switching of the coil can be synchronised with the load current of e.g. the relay.

**PACKAGING INFORMATION QFN16 4 mm x 4 mm**

**PIN CONFIGURATION QFN16 4 mm x 4 mm**

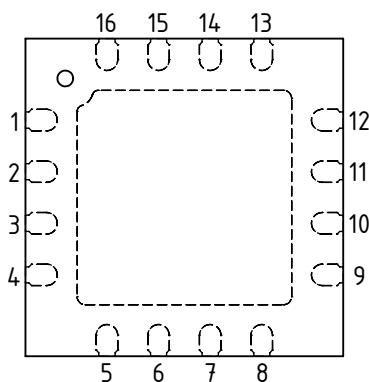

**PIN FUNCTIONS**

No.	Name	Function
1	EN	Enable Input
2	GND	Ground
3	GND	Ground
4	GND	Ground
5	SW	PWM Output
6	SW	PWM Output
7	SW	PWM Output
8	VB	+10...36 V Supply Voltage
9	VB	+10...36 V Supply Voltage
10	VB	+10...36 V Supply Voltage
11	DIAG	Status Output
12	SYNC	Sync Input
13	RM	Reference Ground for RACT and RHOLD
14	TACT	Energising Time Prolongation
15	IHOLD	Hold Current Setup
16	IACT	Energising Current Setup

The *Thermal Pad* is to be connected to a Ground Plane (GND) on the PCB.

**Only pin 1 marking on top or bottom defines the package orientation (Ⓢ GE label and coding is subject to change).**

**PACKAGE DIMENSIONS QFN16 4 mm x 4 mm**

All dimensions given in mm.

**RECOMMENDED PCB-FOOTPRINT**

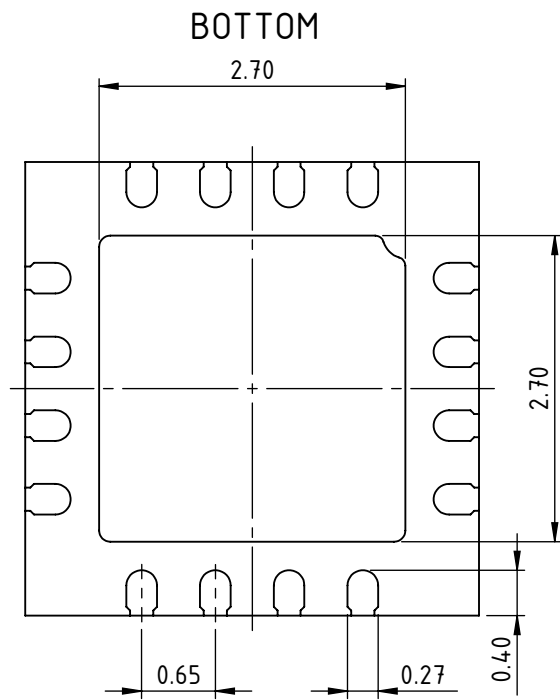
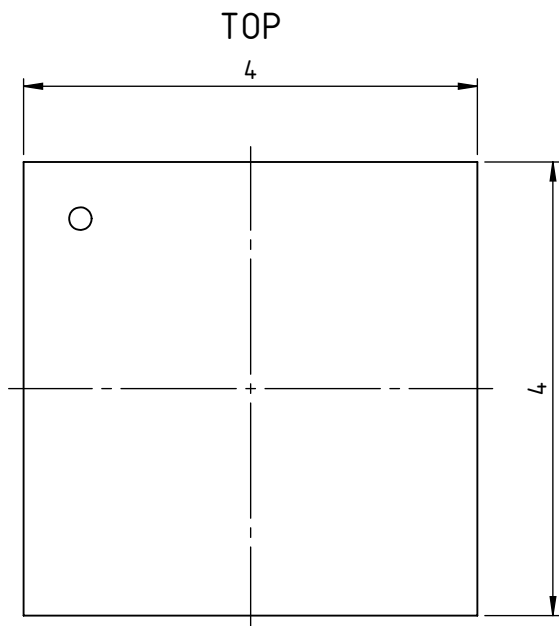
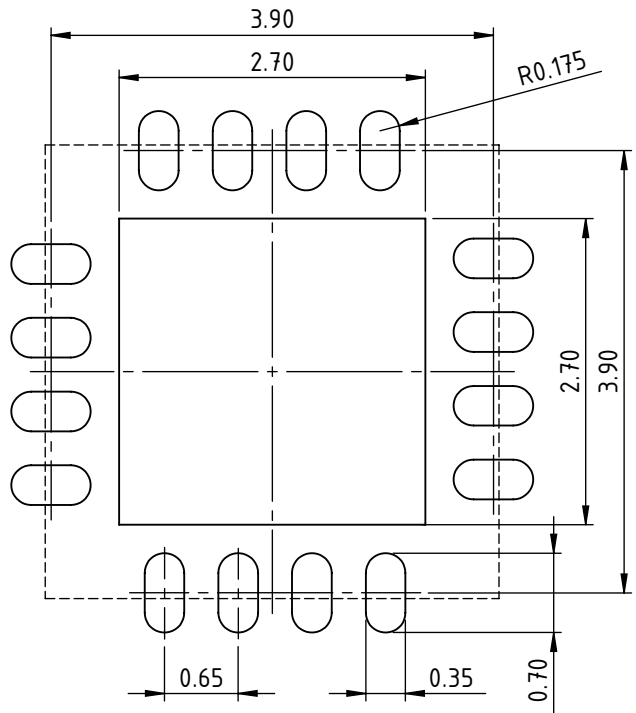
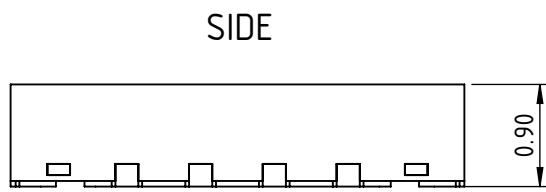

### ABSOLUTE MAXIMUM RATINGS

Beyond these values damage may occur; device operation is not guaranteed.

Item No.	Symbol	Parameter	Conditions	Limits		Unit
				Min.	Max.	
G001	V(VB)	Voltage at VB		-0.3	37	V
G002	I(VB)	Current in VB		-1100	6	mA
G003	V(SW)	Voltage at OUT		-0.3	53	V
G004	I(SW)	Output Current in OUT		-6	1100	mA
G005	V(DIAG)	Voltage at LED		-0.3	37	V
G006	I(DIAG)	Current in LED		-6	8	mA
G007	V(IACT)	Voltage at ISET		-0.3	7	V
G008	I(IACT)	Current in ISET		-6	6	mA
G009	V(IHOLD)	Voltage at IHOLD		-0.3	7	V
G010	I(IHOLD)	Current in IHOLD		-6	6	mA
G011	V(EN)	Voltage at IN		-0.3	37	V
G012	I(EN)	Current in IN		-6	6	mA
G013	V(SYNC)	Voltage at SYNC		-7	37	V
G014	I(SYNC)	Current in SYNC		-6	6	mA
G015	V(TACT)	Voltage at TACT		-0.3	7	V
G016	I(TACT)	Current in TACT		-6	6	mA
G017	V(RM)	Voltage at RM		-0.3	1	V
G018	I(RM)	Current in RM		-6	6	mA
G019	VD()	Susceptibility to ESD at all pins	HBM 100 pf discharged through 1.5 kΩ		2	kV
G020	Tj	Junction Temperature		-40	150	°C
G021	Ts	Storage Temperature		-40	150	°C

### THERMAL DATA

Operating Conditions: VB = 10...36 V, LSW = 0.01...10 H, RACT = 5...50 kΩ, RHOLD = 5...50 kΩ

Item No.	Symbol	Parameter	Conditions	Limits			Unit
				Min.	Typ.	Max.	
T01	Ta	Operating Ambient Temperature Range		-40		85	°C
T02	Rthja	Thermal Resistance Chip/Ambient	Mounted to a PCB, therm. PAD at ca. 2 cm <sup>2</sup> copper area		30	40	K/W

All voltages are referenced to ground unless otherwise stated.

All currents flowing into the device pins are positive; all currents flowing out of the device pins are negative.

**ELECTRICAL CHARACTERISTICS**

 Operating Conditions:  $V_B = 10...36\text{ V}$ ,  $LSW = 0.01...10\text{ H}$ ,  $RACT = 5...50\text{ k}\Omega$ ,  $RHOLD = 5...50\text{ k}\Omega$ ,  $T_j = -40...125\text{ }^\circ\text{C}$ .

Item No.	Symbol	Parameter	Conditions				Unit
				Min.	Typ.	Max.	
<b>Total Device</b>							
001	$V_B$	Permissible Supply Voltage Range		10		36	V
002	$I(V_B)$	Supply Current in $V_B$	$EN < 0.8\text{ V}$			20	$\mu\text{A}$
003	$I(V_B)$	Supply Current in $V_B$	$EN = \text{hi}$	0.5		4	mA
004	$V_c(\text{lo})$	Clamp Voltage lo at all Pins except SYNC	$I() = -4\text{ mA}$ , other Pins open	-1.4		-0.3	V
005	$V_c(\text{lo})$	Clamp Voltage lo an SYNC	$I() = -4\text{ mA}$ , andere Pins offen			-7	V
006	$V_c(\text{hi})$	Clamp Voltage hi at $V_B$ , EN, DIAG, SYNC	$I() = 4\text{ mA}$ , other Pins open	37			V
007	$V_c(\text{hi})$	Clamp Voltage hi at IACT, IHOLD, TACT	$I() = 4\text{ mA}$ , other pins open	7			V
008	$V_c(\text{hi})$	Clamp-Spannung hi an SW	$I(\text{OUT}) = 4\text{ mA}$ , other Pins open	10		17	V
<b>Driver Output SW</b>							
101	$V_s(\text{lo})$	Saturation Voltage lo	$I(\text{SW}) = 1000\text{ mA}$ (see Figure 1)			700	mV
102	$V_s(\text{lo})$	Saturation Voltage lo	$I(\text{SW}) = 100\text{ mA}$ (see Figure 1)			100	mV
103	$I(\text{SW})$	PWM-Current Range		100		1000	mA
104	$I_{sc}()$	Short-circuit Current	$V(\text{SW}) = V_B$	1.1		4	A
105	$V_c(\text{hi})$	Clamp Voltage hi at PWM-Free-Wheeling	$V_c(\text{hi}) = V(\text{SW}) - V_B$ ; $EN = \text{hi}$ , $I(\text{SW}) = 1000\text{ mA}$ (see Figure 1)			600	mV
106	$V_c(\text{hi})$	Clamp Voltage hi at PWM-Free-Wheeling	$V_c(\text{hi}) = V(\text{SW}) - V_B$ ; $EN = \text{hi}$ , $I(\text{SW}) = 100\text{ mA}$ (see Figure 1)			100	mV
107	$V_c(\text{off})$	Clamp Voltage hi at Turn-off	$V_c(\text{hi}) = V(\text{SW}) - V_B$ ; $EN: \text{hi} \rightarrow \text{lo}$ , $I(\text{SW}) = 1000\text{ mA}$ (see Figure 1)	12	15	17	V
108	$I_{IK}()$	Leakage Current	$EN = \text{lo}$ , $V(\text{SW}) = 0...V_B$		1	10	$\mu\text{A}$
109	$t_{\text{won}}(\text{min})$	Minimum PWM Turn-on Duration	$EN = \text{hi}$ , $I(\text{SW}) > I(\text{SW})_{\text{act}}$ resp. $I(\text{SW})_{\text{hold}}$ (see Figure 1)	250		1000	ns
<b>Input EN</b>							
201	$V_t(\text{on})$	Threshold Voltage hi		1.0		1.4	V
202	$V_t(\text{off})$	Threshold Voltage lo		0.8		1.1	V
203	$V_t(\text{hys})$	Hysteresis	$V_t(\text{hys}) = V_t(\text{on}) - V_t(\text{off})$	50			mV
204	$I_{pd}()$	Pull-down Current	$V(\text{EN}) = 0.8...36\text{ V}$			40	$\mu\text{A}$
205	$t_p(\text{VB-SW})$	Turn-on Delay after power-up	$EN = V_B$ , $V_B = V_{\text{Boff}} \rightarrow V_{\text{Bon}}$			40	$\mu\text{s}$
206	$t_p(\text{EN-SW})$	Turn-on Delay	$EN: \text{lo} \rightarrow \text{hi}$ until SW active	30			$\mu\text{s}$
207	$t_p(\text{EN-SW})$	Turn-off Delay	$EN: \text{hi} \rightarrow \text{lo}$ until SW inactive	10			$\mu\text{s}$
208	$t_p(\text{EN-DIAG})$	Delay Time from EN to DIAG = hi or LED permanently on	no error	20			$\mu\text{s}$
<b>Status Monitor DIAG</b>							
401	$I_{pd}()$	Pull-down Current	$V(\text{DIAG}) = 6\text{ V}...V_B$ , SW active, no error	3	5	8	mA
402	$V_{B\text{lo}}$	Permissible Supply Voltage for LED operation at DIAG		6		36	V
403	$V(\text{hi})$	Hi-Level at DIAG	without LED	3.4		5.2	V
404	$f()$	Frequency on Error		1.8	2.4	3.6	Hz
405	$V_s(\text{lo})$	Saturation Voltage lo	$I(\text{DIAG}) = 200\text{ }\mu\text{A}$ , without LED			0.4	V
406	$I_{pu}()$	Pull-up Current	$V(\text{DIAG}) = 0...4\text{ V}$	-120	-100	-70	$\mu\text{A}$
407	$V_{\text{Bon}}$	Turn-on Threshold at $V_B$	$V(\text{DIAG}): \text{lo} \rightarrow \text{hi}$	8	8.5	9	V
408	$V_{\text{Boff}}$	Undervoltage Threshold at $V_B$	Decreasing voltage $V_B$ , $V(\text{DIAG}): \text{hi} \rightarrow \text{lo}$	7.5	8	8.5	V
409	$V_{\text{Bhys}}$	Hysteresis	$V_{\text{Bhys}} = V_{\text{Bon}} - V_{\text{Boff}}$	200	500	800	mV
410	$T_{\text{off}}$	Thermal Shutdown Temperature		140		170	$^\circ\text{C}$
411	$T_{\text{on}}$	Thermal Release Temperature	Decreasing temperature	120		150	$^\circ\text{C}$
412	$T_{\text{hys}}$	Thermal Shutdown Hysteresis	$T_{\text{hys}} = T_{\text{off}} - T_{\text{on}}$	10	20	30	$^\circ\text{C}$

**ELECTRICAL CHARACTERISTICS**

 Operating Conditions:  $V_B = 10...36\text{ V}$ ,  $LSW = 0.01...10\text{ H}$ ,  $R_{ACT} = 5...50\text{ k}\Omega$ ,  $R_{HOLD} = 5...50\text{ k}\Omega$ ,  $T_j = -40...125\text{ }^\circ\text{C}$ .

Item No.	Symbol	Parameter	Conditions				Unit
				Min.	Typ.	Max.	
413	tpACT	Time to error "Energising current not reached"	EN = high $\rightarrow$ DIAG = lo; IACT not reached		10		s
414	tpUV	Time to error "Undervoltage"	EN = high $\rightarrow$ DIAG = lo; $V_B < V_{Bon}$		10		s
<b>Reference IACT and IHOLD</b>							
701	V()	Reference Voltage at IACT and IHOLD		1.21	1.27	1.33	V
702	Isc()	Short-Circuit Current in IACT and IHOLD	$V(ISET) = 0\text{ V}$ or $V(IHOLD) = 0\text{ V}$	-6	-3.7	-2	mA
703	K1	Transfer Value for Energising Current $R_{ACT} = K1 / I(SW)_{act}$	$I(SW)_{act} = 100...1000\text{ mA}$	4500	5000	5500	$\Omega$
704	K2	Transfer Value for Hold Current $R_{HOLD} = K2 / I(SW)_{hold}$	$I(SW)_{hold} = 100...1000\text{ mA}$	4500	5000	5500	$\Omega$
<b>Energising Time Prolongation TACT</b>							
C01	tpPWMlo	Propagation Delay from EN = hi to changeover from IACT to IHOLD	TACT not connected (see Figure 1)	55	65	75	ms
C02	K3	Energising Time Prolongation	$tpPWM = tpPWMlo + K3 * CACT$	0.8	1	1.2	ms/nF
C03	Vth()tact	Threshold at TACT			1.27		V
C04	Vs()	Saturation Voltage at TACT	$I(TACT) = 10\text{ }\mu\text{A}$		20		mV
<b>Oscillator</b>							
J01	fosc	Mean Oscillator Frequency	$(f_{max} + f_{min}) / 2$	60	80	120	kHz
J02	df	Frequency Variation	$(f_{max} - f_{min}) / (2 * f_{osc})$	12		15	%
<b>Synchronisation SYNC</b>							
S01	Vth()sync	Trigger Threshold at SYNC		-40		40	mV
S02	Iik()	Leakage Current	$V(SYNC) = -3\text{ V}...3\text{ V}$	-100		100	nA

**ELECTRICAL CHARACTERISTICS: Diagrams**

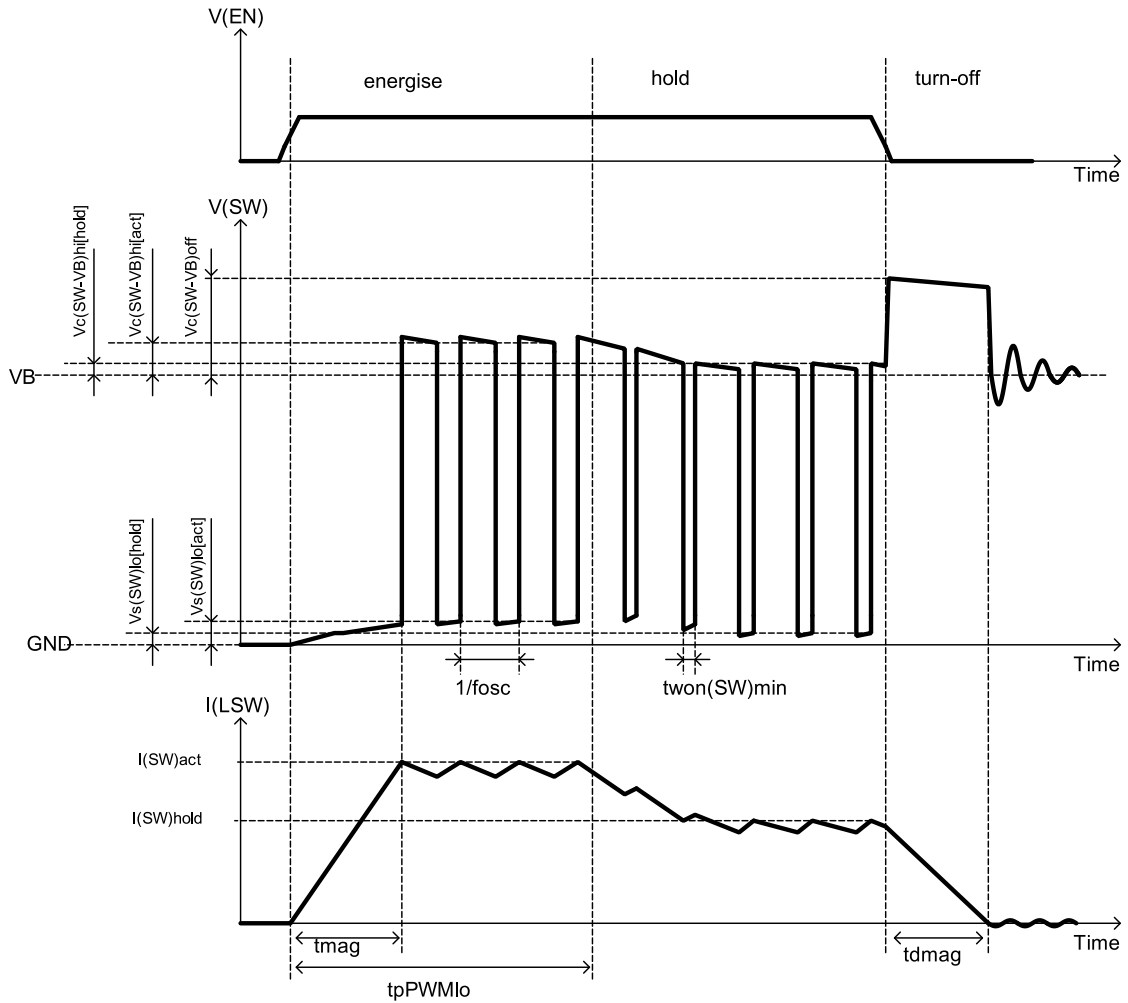

Figure 1: Operation modes *energise*, *hold*, *turn-off*

$$t_{mag} \approx \frac{I(SW)_{act} \times LSW}{VB} \quad (1)$$

$$t_{dmag} \approx \frac{I(SW)_{hold} \times LSW}{V_c(SW - VB)_{off}} \quad (2)$$

### APPLICATIONS INFORMATION

#### Setting the coil current

The following equations can be given for the energise and hold modes of the PWM control using Electrical Characteristics Nos. 703 resp. 704:

$$R_{ACT} = \frac{K1}{I(SW)_{act}} \quad (3)$$

$$R_{HOLD} = \frac{K2}{I(SW)_{hold}} \quad (4)$$

#### Example

For a relay with a starting current of 200 mA and 100 mA hold current the following applies:

$$R_{ACT} = \frac{5 \text{ k}\Omega A}{0.2 \text{ A}} = 25 \text{ k}\Omega \quad (5)$$

$$R_{HOLD} = \frac{5 \text{ k}\Omega A}{0.1 \text{ A}} = 50 \text{ k}\Omega \quad (6)$$

#### Application circuits

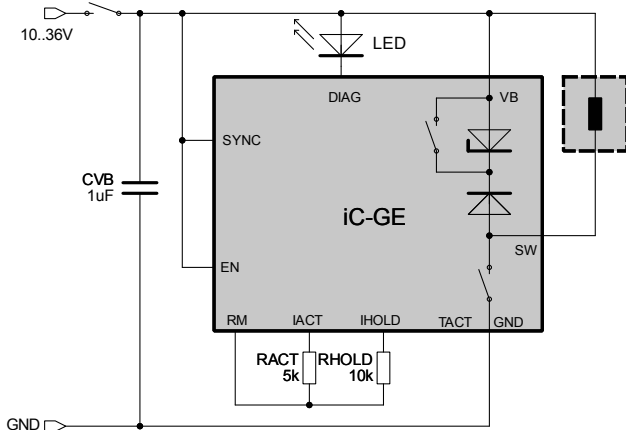

Figure 2: Activation by switching VB  
 $R_{ACT} = 5 \text{ k}\Omega$  for 1 A energising current and  
 $R_{HOLD} = 10 \text{ k}\Omega$  for 500 mA hold current

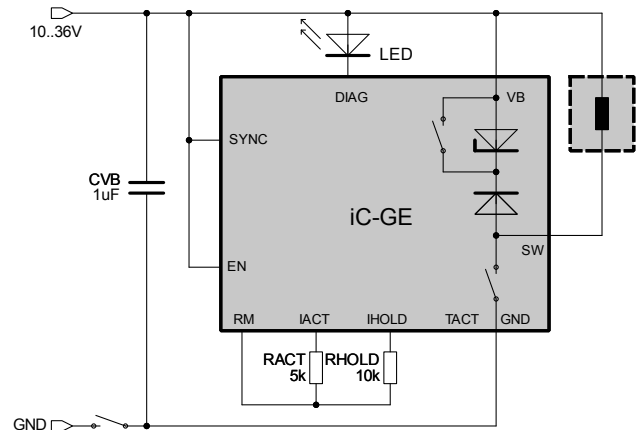

Figure 3: Activation by switching GND

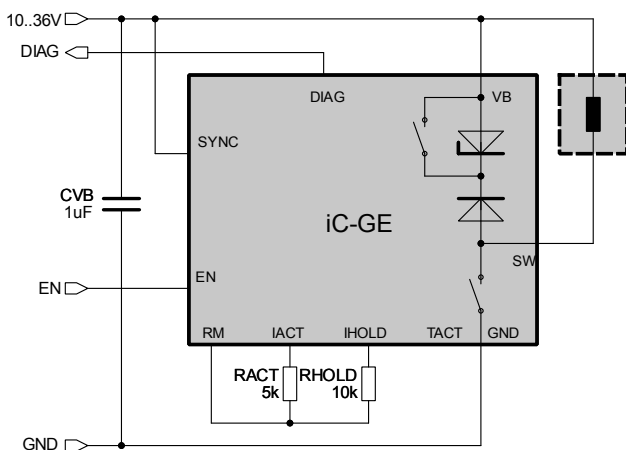

Figure 4: Activation via EN  
 feedback from DIAG with 5 V logic levels

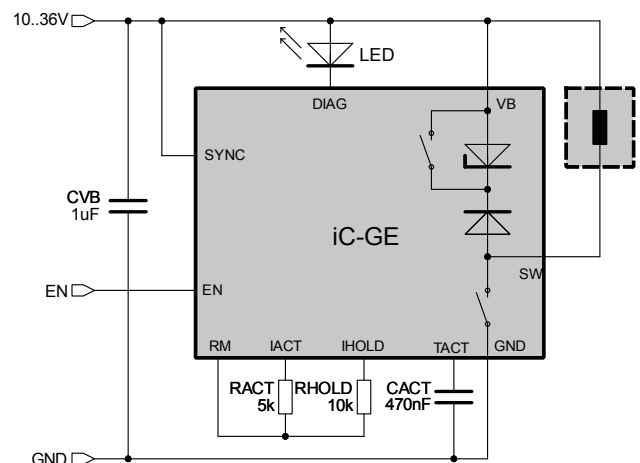

Figure 5: 470 nF for 470 ms energising time prolongation



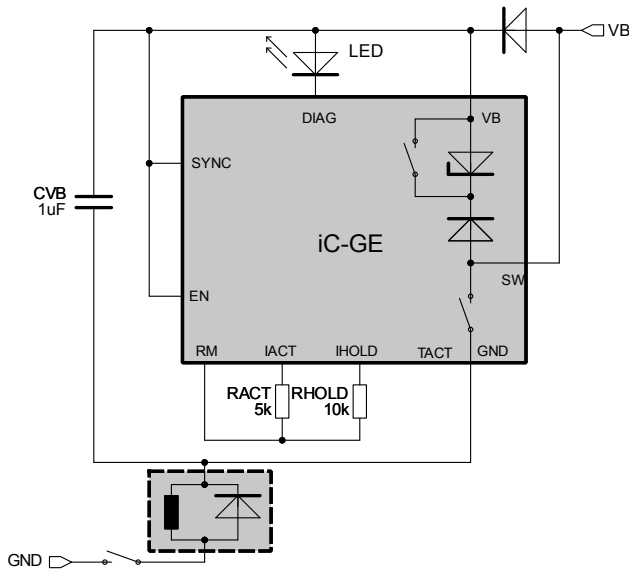

Figure 6: High-side driver for relays with free-wheeling diode

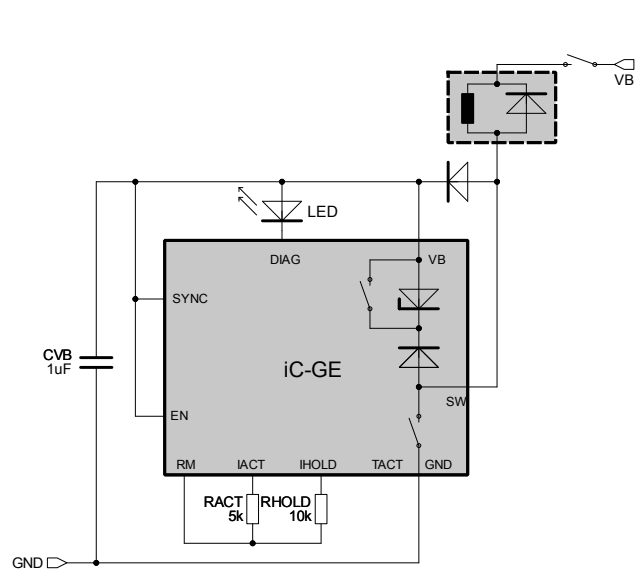

Figure 7: Low-side driver for relays with free-wheeling diode

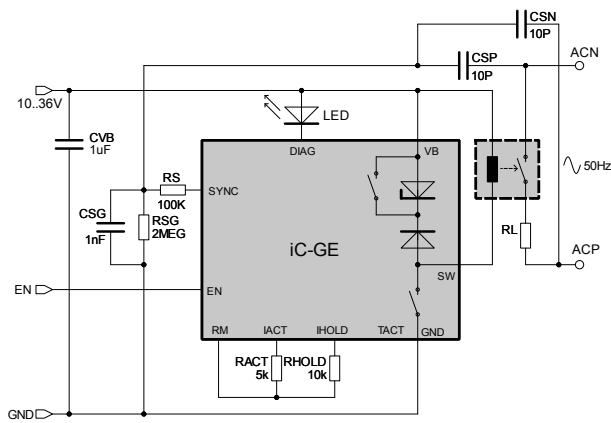

Figure 8: Utilising the SYNC input

By means of resistors  $RS^*$  and capacitors  $CS^*$  a phase shifted signal at SYNC is derived from the 50 Hz load supply.

Thus the relay is activated resp. deactivated with zero crossing of the load supply after working EN.

The phase shift is used to compensate the switching delay of the relay so that the load can be switched at zero current.

The benefit from synchronous switching may be utilised, if the switching times are short and reproducible.

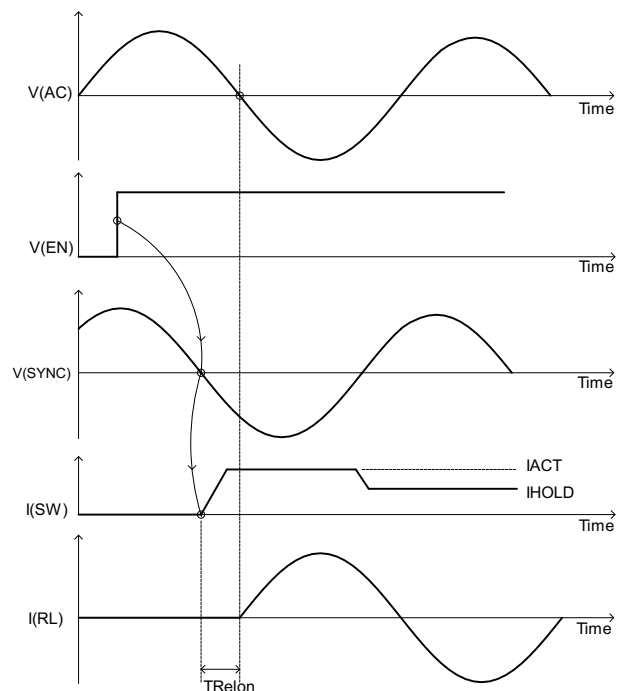

Figure 9: Utilising the SYNC input

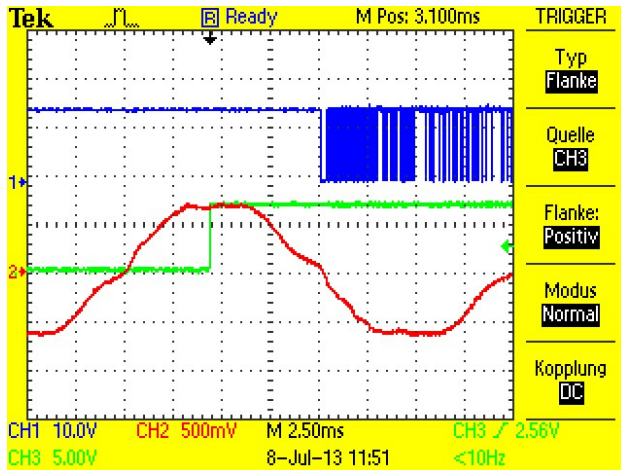

Figure 10: Activation with falling edge of SYNC signal

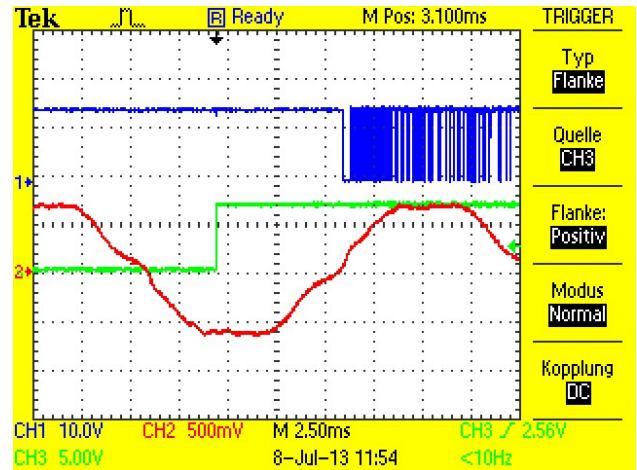

Figure 11: Activation with rising edge of SYNC signal

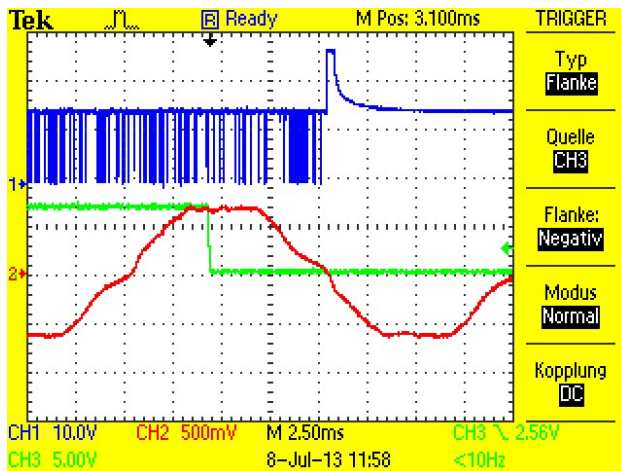

Figure 12: Deactivation with falling edge of SYNC signal

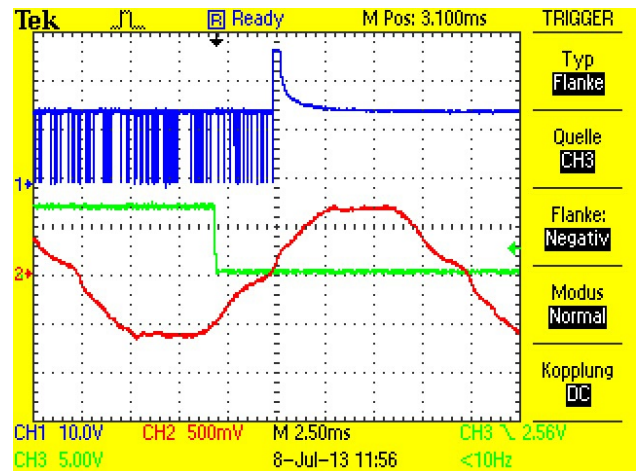

Figure 13: Deactivation with rising edge of SYNC signal

**Application example with four relays of equal acceleration**

REL#	Relay type	REL1	REL2	REL3	REL4	
N	No. of turns	6000	3000	1500	3000	
d	Wire diameter	0.2	0.28	0.4	0.4	mm
VBLn	Nominal coil supply voltage	24	12	6	6	V
VBLmin	Minimum required supply voltage 75% of VBLn	18	9	4.5	4.5	V
VBLmax	Maximum allowed supply voltage VBLn + 25%	30	15	7.5	7.5	V
ISWn	Nominal coil current	208	416	832	416	mA
Ri	Coil resistance at room temperature	115.4	28.8	7.2	14.4	Ω
Rimax	Elevated coil resistance at 80 °C	155	38.8	9.7	19.4	Ω
PvLn	Power dissipation in the coil $VBLn^2 / Ri$	5	5	5	2.5	W

Table 4: Manufacturer data

Imin	Energising current $VBLmin / Rimax$ , for sure switching of the relay at high temperature and low power supply	116	232	464	232	mA
RACT	Calculation: $RACT = K1min / Imin = 4500 / Imin$ , the selected resistor must be smaller then the calculated value	38.8	19.4	9.7	19.4	kΩ
ISWmax	Maximum current is $ISWmax = K1max / RACT = 5500 / RACT$	142	284	567	284	mA
VBLact	Maximum voltage at coil $Rimax * ISWmax$	22.0	11.0	5.5	5.5	V
Vs	Saturation voltage Characteristics No. 101 and No. 102 interpolated, $Vs(lo) * ISWmax / 1000$ mA	0.1	0.2	0.4	0.2	V
VBmin	Minimum supply voltage at iC-GE $VBLact + Vs$	22.1	11.2	10	10	V
VBmax	Maximum supply voltage at iC-GE	36	36	36	36	V
Pv	Power dissipation at PWM $Vs / VBLact$	0.5	1.8	7.3	3.6	%
IVB	Average current in VB for PWM at 24 V $VB ISWmax * VBLact / 24 V * (1 + Pv)$	131	133	139	68	mA
PvL	Power dissipation in the coil $Rimax * ISWmax^2$	3.12	3.12	3.12	1.56	W
PvLhold	Power dissipation at reduced hold current IHOLD of e.g. $2/3 * IACT$	1.39	1.39	1.39	0.7	W

Table 5: iC-GE application

REL1 would be a standard 24 V relay. It could only be used with iC-GE, if operation at 22.1 V can be guaranteed.

REL2 and REL3 are 6/12 V standard relays and thus optimal usable with iC-GE at a 24 V supply voltage.

REL4 is optimised for low power dissipation, since the coils has twice the number of turns than REL3 and a  $\sqrt{2}$  wider diameter than REL2. Thus the power dissipation in the coil is halved.

By means of the optimised power control e.g. with a permanently-on 24 V mains-insulation relay of photovoltaic or heating systems up to

$$(5 W - 0.7 W) * 24 h * 365 days = 37.7 kWh$$

may be saved per year.

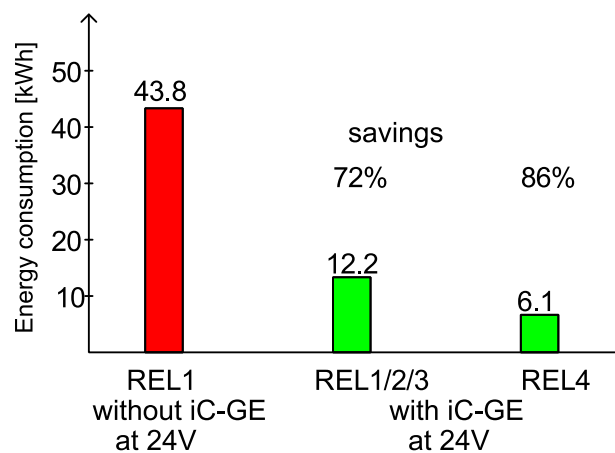

Figure 14: Energy savings

### EVALUATION BOARD

iC-GE comes with an evaluation board for test purpose. Figures 15 and 16 show both the schematic and the component side of the evaluation board.

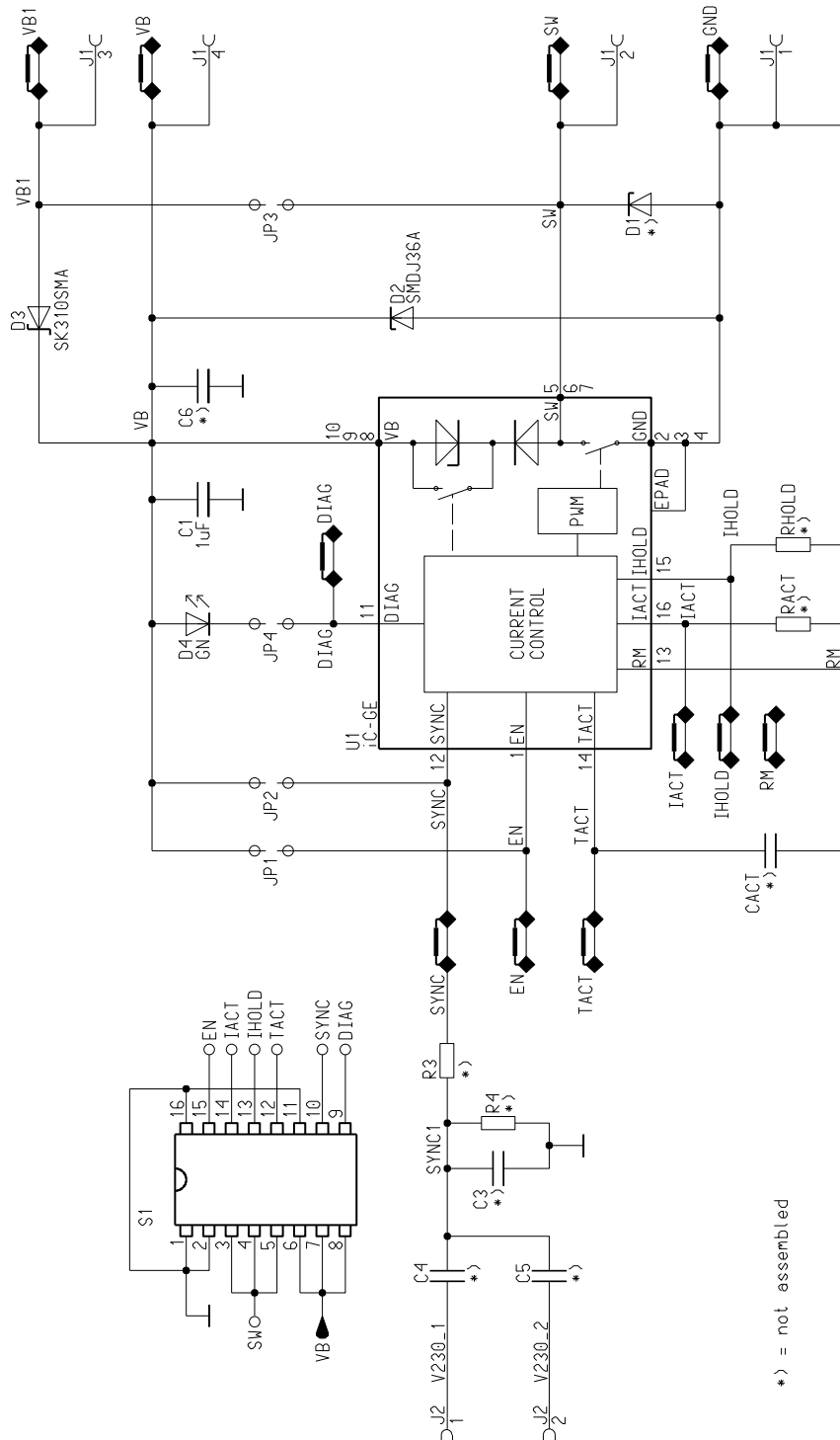

Figure 15: Schematic of the evaluation board

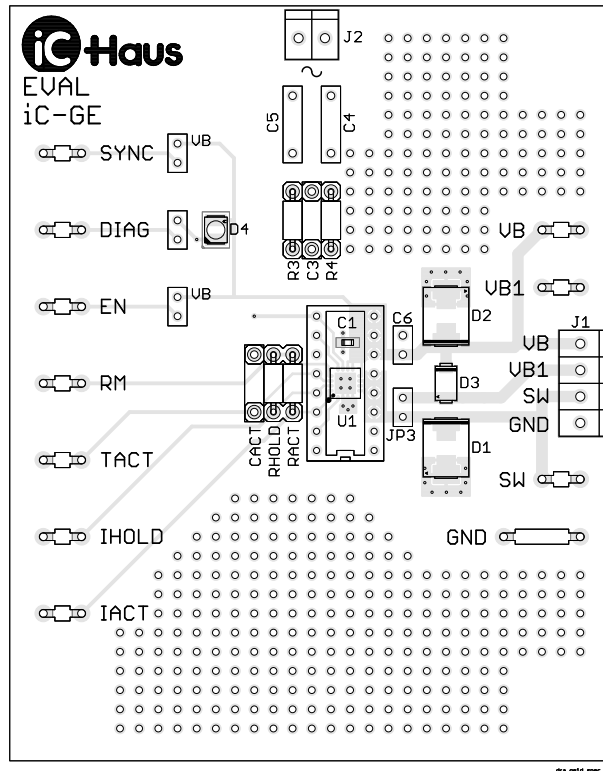

Figure 16: Evaluation board (component side)

iC-Haus expressly reserves the right to change its products and/or specifications. An info letter gives details as to any amendments and additions made to the relevant current specifications on our internet website [www.ichaus.de/infoletter](http://www.ichaus.de/infoletter); this letter is generated automatically and shall be sent to registered users by email.

Copying – even as an excerpt – is only permitted with iC-Haus' approval in writing and precise reference to source.

iC-Haus does not warrant the accuracy, completeness or timeliness of the specification and does not assume liability for any errors or omissions in these materials.

The data specified is intended solely for the purpose of product description. No representations or warranties, either express or implied, of merchantability, fitness for a particular purpose or of any other nature are made hereunder with respect to information/specification or the products to which information refers and no guarantee with respect to compliance to the intended use is given. In particular, this also applies to the stated possible applications or areas of applications of the product.

iC-Haus conveys no patent, copyright, mask work right or other trade mark right to this product. iC-Haus assumes no liability for any patent and/or other trade mark rights of a third party resulting from processing or handling of the product and/or any other use of the product.

**ORDERING INFORMATION**

Type	Package	Order Designation
iC-GE	QFN16 4 mm x 4 mm	iC-GE QFN16-4x4
iC-GE	Evaluation Board	iC-GE EVAL GE1D

For technical support, information about prices and terms of delivery please contact:

**iC-Haus GmbH**  
Am Kuemmerling 18  
D-55294 Bodenheim  
GERMANY

**Tel.: +49 (0) 61 35-9292-0**  
**Fax: +49 (0) 61 35-9292-192**  
**Web: <http://www.ichaus.com>**  
**E-Mail: [sales@ichaus.com](mailto:sales@ichaus.com)**

**Appointed local distributors: [http://www.ichaus.com/sales\\_partners](http://www.ichaus.com/sales_partners)**